

SERVICE MANUAL



L56
DVD/VIDEO CD/CD
PLAYER

L56

DVD/VIDEO CD/CD
PLAYER

SECTION 1

SUMMARY

CONTENTS

PRODUCT SAFETY SERVICING GUIDELINES FOR VIDEO PRODUCTS	1-3
SERVICING PRECAUTIONS	1-4
•General Servicing Precautions	
•Insulation Checking Prodedure	
•Electrostatically Sensitive Devices	
SPECIFICATIONS	1-5
LOCATION OF CUSTOMER CONTROLS	1-6
EXPLODED VIEWS	1-9

PRODUCT SAFETY SERVICING GUIDELINES FOR VIDEO PRODUCTS

CAUTION : DO NOT ATTEMPT TO MODIFY THIS PRODUCT IN ANY WAY. NEVER PERFORM CUSTOMIZED INSTALLATIONS WITHOUT MANUFACTURER'S APPROVAL. UNAUTHORIZED MODIFICATIONS WILL NOT ONLY VOID THE WARRANTY, BUT MAY LEAD TO YOUR BEING LIABLE FOR ANY RESULTING PROPERTY DAMAGE OR USER INJURY.

SERVICE WORK SHOULD BE PERFORMED ONLY AFTER YOU ARE THOROUGHLY FAMILIAR WITH ALL OF THE FOLLOWING SAFETY CHECKS AND SERVICING GUIDELINES. TO DO OTHERWISE, INCREASES THE RISK OF POTENTIAL HAZARDS AND INJURY TO THE USER.

WHILE SERVICING, USE AN ISOLATION TRANSFORMER FOR PROTECTION FROM A.C. LINE SHOCK.

SAFETY CHECKS

AFTER THE ORIGINAL SERVICE PROBLEM HAS BEEN CORRECTED. A CHECK SHOULD BE MADE OF THE FOLLOWING.

SUBJECT : FIRE & SHOCK HAZARD

1. BE SURE THAT ALL COMPONENTS ARE POSITIONED IN SUCH A WAY AS TO AVOID POSSIBILITY OF ADJACENT COMPONENT SHORTS. THIS IS ESPECIALLY IMPORTANT ON THOSE MODULES WHICH ARE TRANSPORTED TO AND FROM THE REPAIR SHOP.
2. NEVER RELEASE A REPAIR UNLESS ALL PROTECTIVE DEVICES SUCH AS INSULATORS, BARRIERS, COVERS, SHIELDS, STRAIN RELIEFS, POWER SUPPLY CORDS, AND OTHER HARDWARE HAVE BEEN REINSTALLED PER ORIGINAL DESIGN. BE SURE THAT THE SAFETY PURPOSE OF THE POLARIZED LINE PLUG HAS NOT BEEN DEFEATED.
3. SOLDERING MUST BE INSPECTED TO DISCOVER POSSIBLE COLD SOLDER JOINTS, SOLDER SPLASHES OR SHARP SOLDER POINTS. BE CERTAIN TO REMOVE ALL LOOSE FOREIGN PARTICLES.
4. CHECK FOR PHYSICAL EVIDENCE OF DAMAGE OR DETERIORATION TO PARTS AND COMPONENTS. FOR FRAYED LEADS, DAMAGED INSULATION (INCLUDING A.C. CORD). AND REPLACE IF NECESSARY FOLLOW ORIGINAL LAYOUT, LEAD LENGTH AND DRESS.
5. NO LEAD OR COMPONENT SHOULD TOUCH A RECEIVING TUBE OR A RESISTOR RATED AT 1 WATT OR MORE. LEAD TENSION AROUND PROTRUDING METAL SURFACES MUST BE AVOIDED.
6. ALL CRITICAL COMPONENTS SUCH AS FUSES, FLAMEPROOF RESISTORS, CAPACITORS, ETC. MUST BE REPLACED WITH EXACT FACTORY TYPES, DO NOT USE REPLACEMENT COMPONENTS OTHER THAN THOSE SPECIFIED OR MAKE UNRECOMMENDED CIRCUIT MODIFICATIONS.
7. AFTER RE-ASSEMBLY OF THE SET ALWAYS PERFORM AN A.C. LEAKAGE TEST ON ALL EXPOSED METALLIC PARTS OF THE CABINET, (THE CHANNEL SELECTOR KNOB, ANTENNA TERMINALS. HANDLE AND SCREWS) TO BE SURE THE SET IS SAFETY TO OPERATE WITHOUT DANGER OF ELECTRICAL SHOCK. DO NOT USE A LINE ISOLATION TRANSFORMER DURING THIS TEST USE AN A.C. VOLTMETER, HAVING 5000 OHMS PER VOLT OR MORE SENSITIVITY, IN THE FOLLOWING MANNER; CONNECT A 1500 OHM 10 WATT RESISTOR, PARALLELED BY A .15 MFD, 150.V A.C TYPE CAPACITOR BETWEEN A KNOWN GOOD EARTH GROUND (WATER PIPE, CONDUIT, ETC.) AND THE EXPOSED METALLIC PARTS, ONE AT A TIME. MEASURE THE A.C. VOLTAGE ACROSS THE COMBINATION OF 1500 OHM RESISTOR AND .15 MFD CAPACITOR. REVERSE THE A.C. PLUG AND REPEAT A.C. VOLTAGE MEASUREMENTS FOR EACH EXPOSED METALLIC PART.

VOLTAGE MEASURE MUST NOT EXCEED 75 VOLTS R.M.S. THIS CORRESPONDS TO 0.5 MILLIAMPS A.C ANY VALUE EXCEEDING THIS LIMIT CONSTITUTES A POTENTIAL SHOCK HAZARD AND MUST BE CORRECTED IMMEDIATELY.

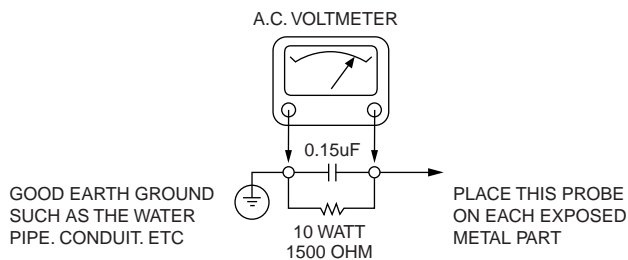

SUBJECT : GRAPHIC SYMBOLS



THE LIGHTNING FLASH WITH ARROWHEAD SYMBOL, WITHIN AN EQUILATERAL TRIANGLE, IS INTENDED TO ALERT THE USER TO THE PRESENCE OF UNINSULATED "DANGEROUS VOLTAGE" WITHIN THE PRODUCT'S ENCLOSURE THAT MAY BE OF SUFFICIENT MAGNITUDE TO CONSTITUTE A RISK OF ELECTRIC SHOCK.



THE EXCLAMATION POINT WITHIN AN EQUILATERAL TRIANGLE IS INTENDED TO ALERT THE USER TO THE PRESENCE OF IMPORTANT OPERATING AND MAINTENANCE (SERVICING) INSTRUCTIONS IN THE LITERATURE ACCOMPANYING THE APPLIANCE.

SUBJECT : TIPS ON PROPER INSTALLATION

1. NEVER INSTALL ANY PRODUCT IN A CLOSED-IN RECESS, CUBBYHOLE OR CLOSELY FITTING SHELF SPACE. OVER OR CLOSE TO HEAT DUCT, OR IN THE PATH OF HEATED AIR FLOW.
2. AVOID CONDITIONS OF HIGH HUMIDITY SUCH AS: OUTDOOR PATIO INSTALLATIONS WHERE DEW IS A FACTOR, NEAR STEAM RADIATORS WHERE STEAM LEAKAGE IS A FACTOR, ETC.
3. AVOID PLACEMENT WHERE DRAPERIES MAY OBSTRUCT REAR VENTING. THE CUSTOMER SHOULD ALSO AVOID THE USE OF DECORATIVE SCARVES OR OTHER COVERINGS WHICH MIGHT OBSTRUCT VENTILATION.
4. WALL AND SHELF MOUNTED INSTALLATIONS USING A COMMERCIAL MOUNTING KIT MUST FOLLOW THE FACTORY APPROVED MOUNTING INSTRUCTIONS A PRODUCT MOUNTED TO A SHELF OR PLATFORM MUST RETAIN ITS ORIGINAL FEET (OR THE EQUIVALENT THICKNESS IN SPACERS) TO PROVIDE ADEQUATE AIR FLOW ACROSS THE BOTTOM, BOLTS OR SCREWS USED FOR FASTENERS MUST NOT TOUCH ANY PARTS OR WIRING. PERFORM LEAKAGE TEST ON CUSTOMIZED INSTALLATIONS.
5. CAUTION CUSTOMERS AGAINST THE MOUNTING OF A PRODUCT ON SLOPING SHELF OR A TILTED POSITION, UNLESS THE PRODUCT IS PROPERLY SECURED.
6. A PRODUCT ON A ROLL-ABOUT CART SHOULD BE STABLE ON ITS MOUNTING TO THE CART. CAUTION THE CUSTOMER ON THE HAZARDS OF TRYING TO ROLL A CART WITH SMALL CASTERS ACROSS THRESHOLDS OR DEEP PILE CARPETS.
7. CAUTION CUSTOMERS AGAINST THE USE OF A CART OR STAND WHICH HAS NOT BEEN LISTED BY UNDERWRITERS LABORATORIES, INC. FOR USE WITH THEIR SPECIFIC MODEL OF TELEVISION RECEIVER OR GENERICALLY APPROVED FOR USE WITH T.V.'S OF THE SAME OR LARGER SCREEN SIZE.
8. CAUTION CUSTOMERS AGAINST THE USE OF EXTENSION CORDS, EXPLAIN THAT A FOREST OF EXTENSIONS SPROUTING FROM A SINGLE OUTLET CAN LEAD TO DISASTROUS CONSEQUENCES TO HOME AND FAMILY.

SERVICING PRECAUTIONS

CAUTION : Before servicing the DVD player covered by this service data and its supplements and addends, read and follow the **SAFETY PRECAUTIONS**. **NOTE** : if unforeseen circumstances create conflict between the following servicing precautions and any of the safety precautions in this publication, always follow the safety precautions.

Remember Safety First:

General Servicing Precautions

1. Always unplug the DVD player's AC power cord from the AC power source before:
 - (1) Removing or reinstalling any component, circuit board, module, or any other assembly.
 - (2) Disconnecting or reconnecting any internal electrical plug or other electrical connection.
 - (3) Connecting a test substitute in parallel with an electrolytic capacitor.

Caution : A wrong part substitution or incorrect polarity installation of electrolytic capacitors may result in an explosion hazard.
2. Do not spray chemicals on or near this DVD player or any of its assemblies.
3. Unless specified otherwise in this service data, clean electrical contacts by applying an appropriate contact cleaning solution to the contacts with a pipe cleaner, cottontipped swab, or comparable soft applicator.
Unless specified otherwise in this service data, lubrication of contacts is not required.
4. Do not defeat any plug/socket B+ voltage interlocks with which instruments covered by this service manual might be equipped.
5. Do not apply AC power to this DVD player and/or any of its electrical assemblies unless all solid-state device heat sinks are correctly installed.
6. Always connect test instrument ground lead to the appropriate ground before connecting the test instrument positive lead. Always remove the test instrument ground lead last.

Insulation Checking Procedure

Disconnect the attachment plug from the AC outlet and turn the power on. Connect an insulation resistance meter(500V) to the blades of the attachment plug. The insulation resistance between each blade of the attachment plug and accessible conductive parts (Note 1) should be more than 1M-ohm.

Note 1 : Accessible Conductive Parts including Metal panels, Input terminals, Earphone jacks, etc.

Electrostatically Sensitive (ES) Devices

Some semiconductor (solid state) devices can be damaged easily by static electricity. Such components commonly are called Electrostatically Sensitive (ES) Devices. Examples of typical Es devices are integrated circuits and some field effect transistors and semiconductor chip components.

The following techniques should be used to help reduce the incidence of component damage caused by static electricity.

1. Immediately before handling any semiconductor component or semiconductor-equipped assembly, drain off any electrostatic charge on your body by touching a known earth ground. Alternatively, obtain and wear a commercially available discharging wrist strap device, which should be removed for potential shock reasons prior to applying power to the unit under test.
2. After removing an electrical assembly equipped with ES devices, place the assembly on a conductive surface such as aluminum foil, to prevent electrostatic charge buildup or exposure of the assembly.
3. Use only a grounded-tip soldering iron to solder or unsolder ES devices.
4. Use only an antistatic solder removal device. Some solder removal devices not classified a "anti-static" can generate electrical charges sufficient to damage ES devices.
5. Do not use freonpropelled chemicals. These can generate electrical charge sufficient to damage ES devices.
6. Do not remove a replacement ES device from its protective package until immediately before you are ready to install it. (Most replacement ES devices are packaged with leads electrically shorted together by conductive foam, aluminum foil, or comparable conductive material).
7. Immediately before removing the protective material from the leads of a replacement ES device, touch the protective material to the chassis or circuit assembly into which the device will be installed.

Caution : Be sure no power is applied to the chassis or circuit, and observe all other safety precautions.

8. Minimize bodily motions when handing unpackaged replacement ES devices. (Normally harmless motion such as the brushing together of your clothes fabric or the lifting of your foot from a carpeted floor can generate static electricity sufficient to damage an ES device.)

SPECIFICATIONS

DVD player/Outputs/Supplied Accessories

[DVD player]	Power supply	AC 230V / 50 Hz (EUROPE), AC 110V/60Hz (USA / CANADA)
	Power consumption	15 W
	Mass	3.3 kg
	External dimensions (W X H X D)	285 x 103x 291 mm
	Signal system	PAL (EUR) , NTSC (USA / CANADA)
	Laser	Semiconductor laser, wavelength 650 nm
	Frequency range (audio)	4 Hz to 20 kHz
	Signal-to-noise ratio (audio)	More than 100 dB (EIAJ)
	Dynamic range (audio)	More than 95 dB (EIAJ)
	Harmonic distortion (audio)	0.008 %
	Wow and flutter	Below measurable level (less than + 0.001 % (W.PEAK)) (EIAJ)
	Operating conditions	Temperature: 41°F to 95°F, Operation status: Horizontal
[Outputs]	Video output	1.0 V (p-p), 75 Ω , negative sync., RCA jack x 1
	S-video output	(Y) 1.0 V (p-p), 75 Ω , negative sync., Mini DIN 4-pin x 1 (C) 0.286 V (p-p), 75 Ω ,
	SCART video output	CVBS 1.0 V (p-p), 75 Ω , negative sync., RCA jack x 1 (RGB) 0.63 V (p-p), 75 Ω
	Audio output (digital audio)	0.5 V (p-p), 75 Ω , RCA jack x 1
	Audio output (optical audio)	Optical connector x 1
	Audio output (analog audio)	2.0 Vrms(1 KHz, 0 dB), 330 Ω , RCA jack (L, R) x 1
[Supplied Accessories]	<ul style="list-style-type: none"> ● Video cable. 1 ● Audio cable. 1 	

* Designs and specifications are subject to change without notice.

LOCATION OF CUSTOMER CONTROLS

Front Panel

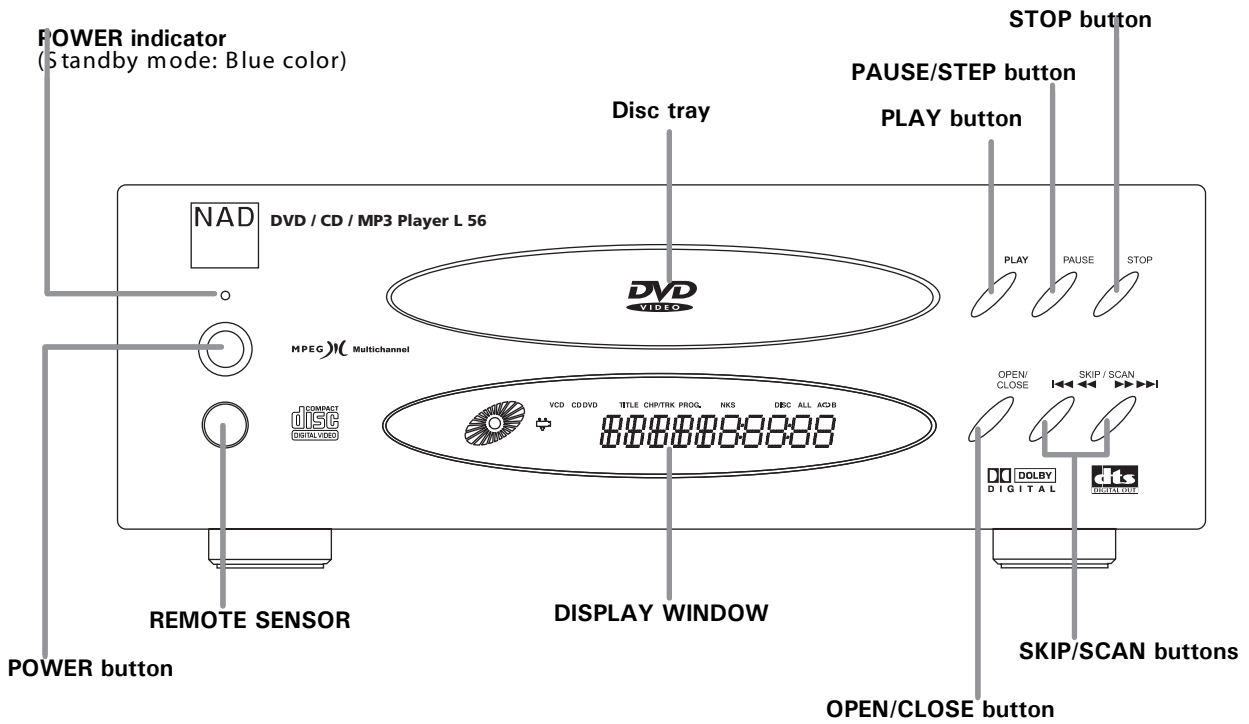

Display Window

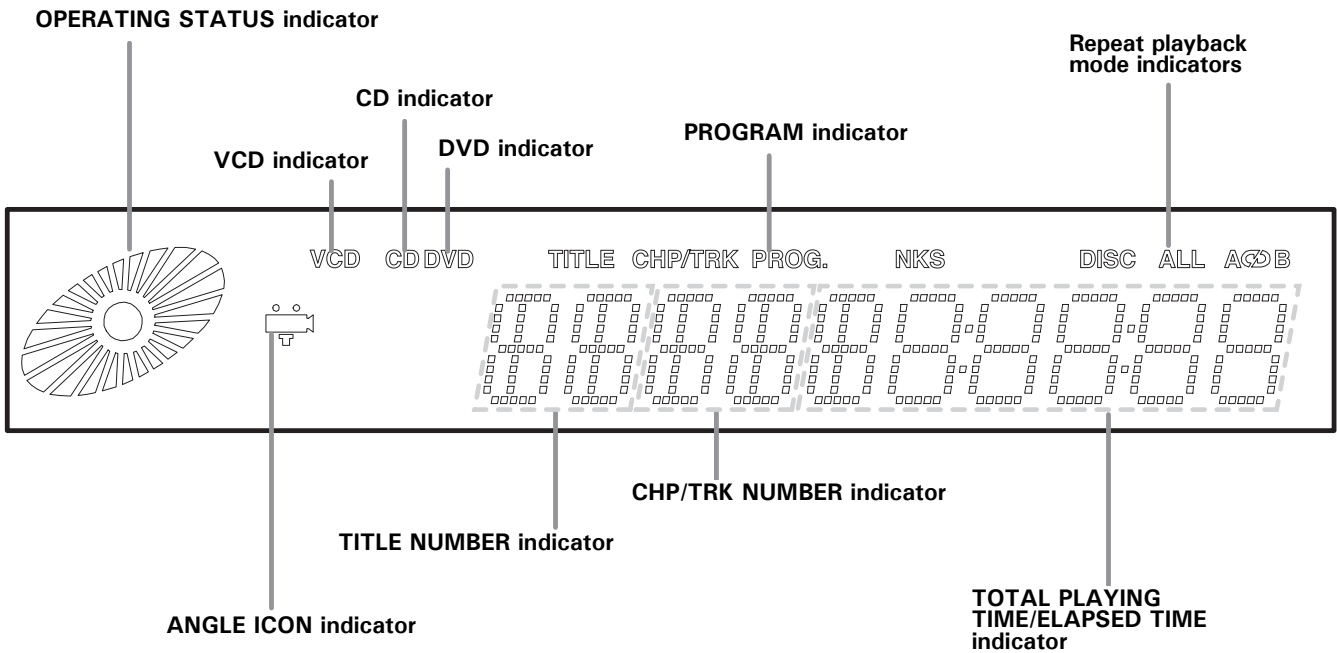

REMOTE CONTROL

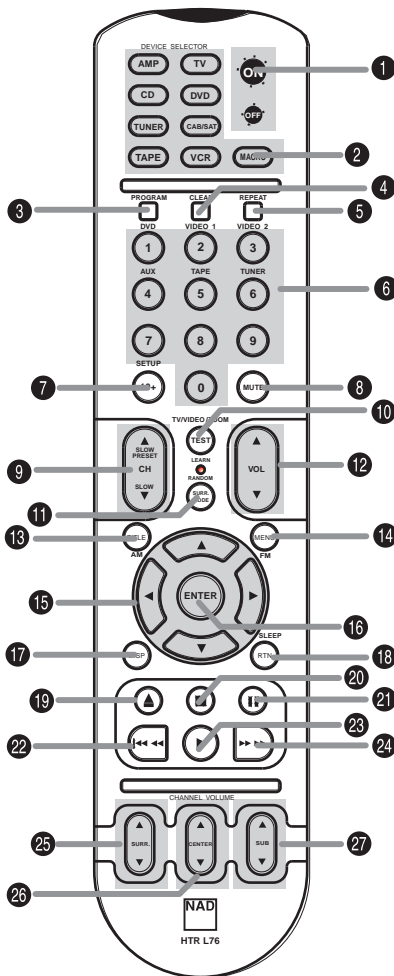

1. POWER ON/OFF button (L76/L56)
2. DEVICE SELECTOR buttons
3. PROGRAM buttons (L56)
4. CLEAR button (L56)
5. REPEAT button (L56)
6. INPUT SOURCE SELECTOR buttons(L76), NUMERIC buttons (L76/L56)
7. OSD ON/OFF buttons (L76), DVD SET UP button (L56)
8. MUTE button (L76)
9. PRESET UP/DOWN buttons (L76), SLOW buttons (L56)
10. TEST TONE button (L76), ZOOM button (L56)
11. SURROUND MODE button (L76), RANDOM button (L56)
12. VOLUME UP/DOWN buttons (L76)
13. AM button (L76), TITLE button (L56)
14. FM button (L76), MENU button (L56)
15. ARROW buttons (L76/L56)
16. ENTER button (L76/L56)
17. DIGITAL INPUT/ RDS button (L76), DVD DISPLAY button (L56)
18. SLEEP button (L76), RETURN button (L56)
19. OPEN/CLOSE button (L56)
20. STOP button (L56)
21. PAUSE button (L56)
22. REV SCAN/SKIP button (L56)
23. PLAY button (L56)
24. FOR SCAN/ SKIP button (L56)
25. SURROUND LEVEL UP/DOWN buttons (L76)
26. CENTER LEVEL UP/DOWN buttons (L76)
27. SUBWOOFER LEVEL UP/DOWN buttons (L76)

EXPLODED VIEW(L56C)

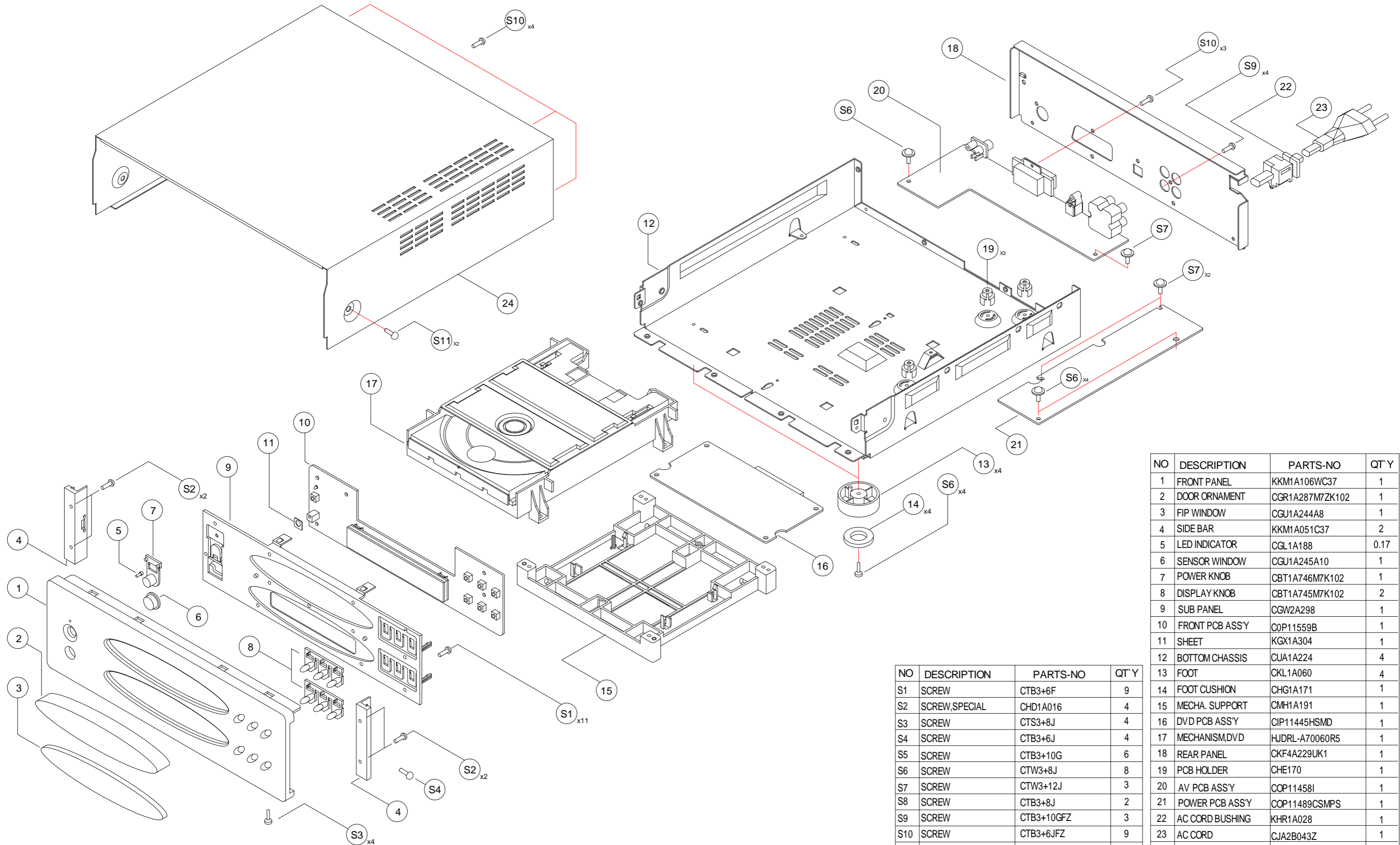

NO	DESCRIPTION	PARTS-NO	QTY
1	FRONT PANEL	KKM1A106WC37	1
2	DOOR ORNAMENT	CGR1A287M7ZK102	1
3	FIP WINDOW	CGU1A244A8	1
4	SIDE BAR	KKM1A051C37	2
5	LED INDICATOR	CGL1A188	0.17
6	SENSOR WINDOW	CGU1A245A10	1
7	POWER KNOB	CBT1A746M7K102	1
8	DISPLAY KNOB	CBT1A745M7K102	2
9	SUB PANEL	CGW2A298	1
10	FRONT PCB ASS'Y	COP11559B	1
11	SHEET	KGX1A304	1
12	BOTTOM CHASSIS	CUA1A224	4
13	FOOT	CKL1A060	4
14	FOOT CUSHION	CHG1A171	1
15	MECHA. SUPPORT	CMH1A191	1
16	DVD PCB ASS'Y	CIP11445HSMD	1
17	MECHANISM,DVD	HJDRL-A70060R5	1
18	REAR PANEL	CKF4A229UK1	1
19	PCB HOLDER	CHE170	1
20	AV PCB ASS'Y	COP11458I	1
21	POWER PCB ASS'Y	COP11489CSMPS	1
22	AC CORD BUSHING	KHR1A028	1
23	AC CORD	CJA2B043Z	1
24	TOP CABINET	CKC1B127S35	1
S1	SCREW	CTB3+6F	9
S2	SCREW,SPECIAL	CHD1A016	4
S3	SCREW	CTS3+8J	4
S4	SCREW	CTB3+6J	4
S5	SCREW	CTB3+10G	6
S6	SCREW	CTW3+8J	8
S7	SCREW	CTW3+12J	3
S8	SCREW	CTB3+8J	2
S9	SCREW	CTB3+10GFZ	3
S10	SCREW	CTB3+6JFZ	9
S11	SCREW	CTB4+6JFZ	2

SECTION 2 ELECTRICAL CONTENTS

ELECTRICAL TROUBLESHOOTING GUIDE.....	2-2
1. Power (SMPS) Circuit.....	2-2
2. μ -com Circuit.....	2-3
3. MPEG Circuit.....	2-6
4. Front Circuit (Digitron & Key)	2-7
5. RF/Servo Circuit	2-8
BLOCK DIAGRAMS	2-12
1. Overall Block Diagram	2-12
2. Power (SMPS) Block Diagram.....	2-13
3. RF/CD DSP/DVD DSP/DVD servo Block Diagram	2-14
4. Audio Block Diagram	2-15
5. MPEG Block Diagram.....	2-16
6. μ -COM Block Diagram.....	2-17
CIRCUIT DIAGRAMS	2-18
1. Power (SMPS) Circuit Diagram	2-18
2. DVD DSP Circuit Diagram	2-20
3. Drive & RF Circuit Diagram	2-22
4. MPEG Circuit Diagram	2-24
4-1. WAVEFORMS	2-26
5. Audio DM & 5.1CH Circuit Diagram	2-28
6. μ -COM/Expander	2-30
7. DIGITRON & Key Circuit Diagram	2-32
8. Jack Circuit Diagram	2-34
PRINTED CIRCUIT DIAGRAMS	2-36
1. MAIN P.C.BOARD	2-36
2. POWER P.C.BOARD.....	2-38
3. AV P.C.BOARD	2-40
4. FRONT P.C.BOARD	2-42

ELECTRICAL TROUBLESHOOTING GUIDE

1. POWER (SMPS) Circuit

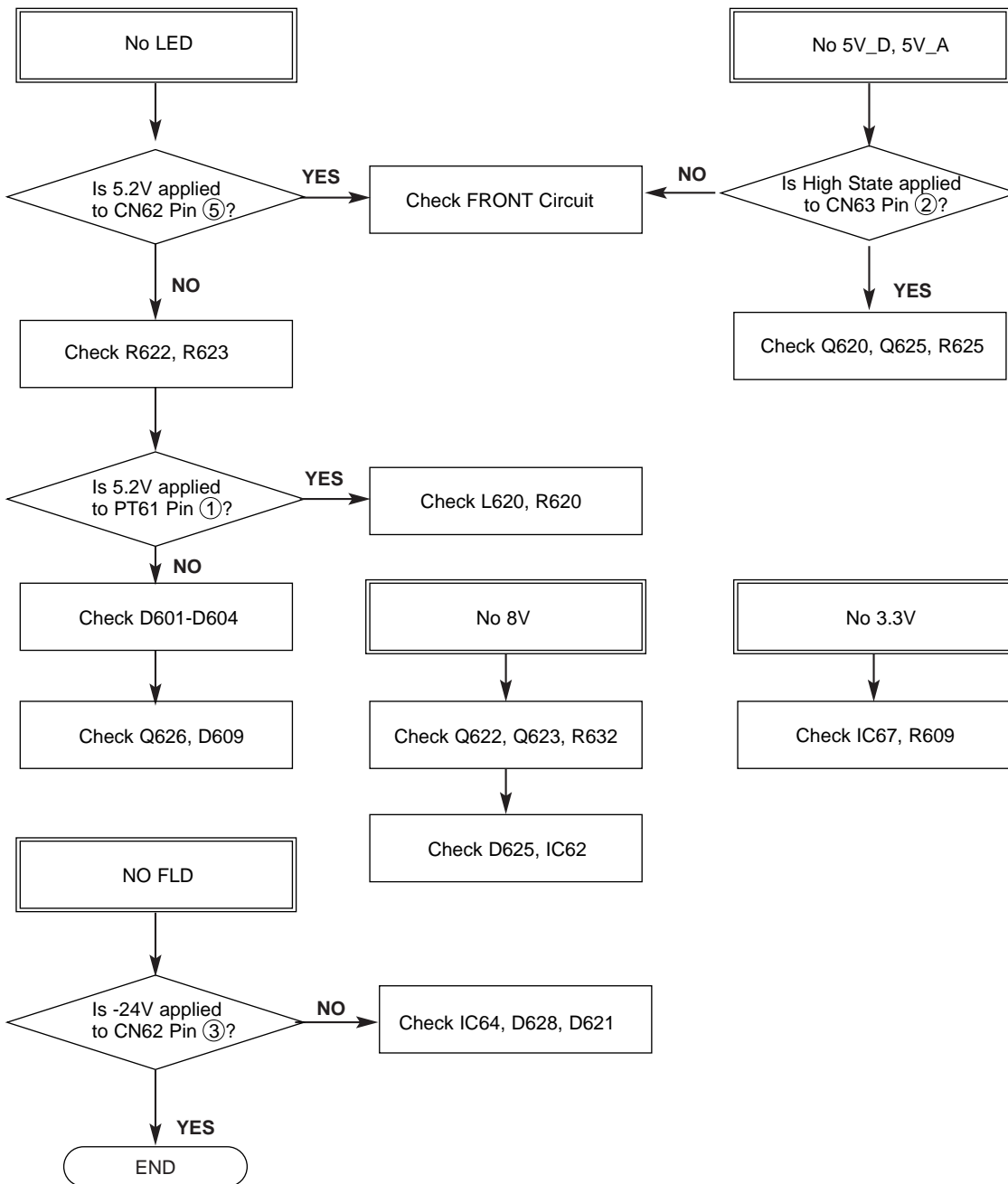

2. u-COM Circuit

A. NO Power

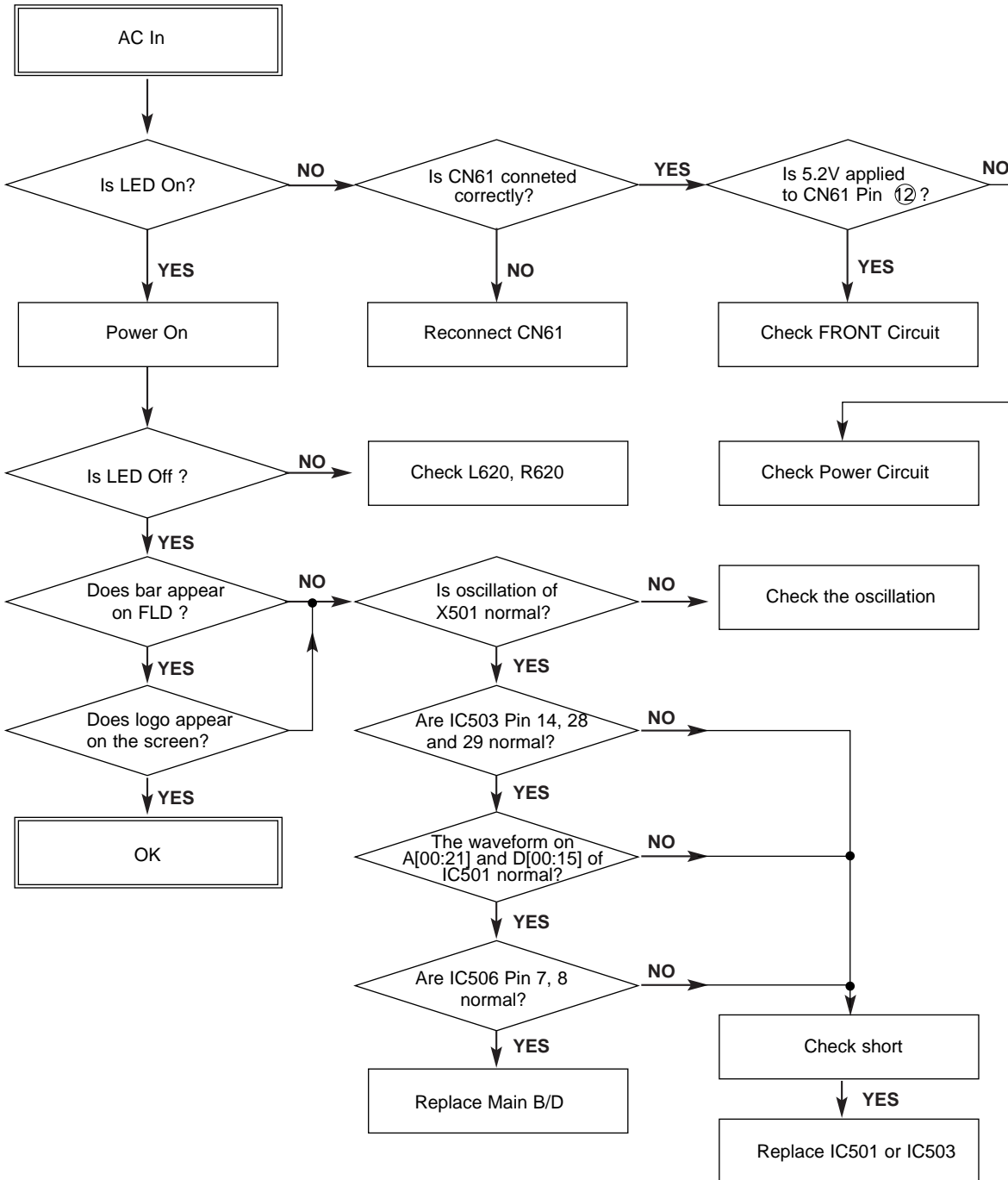

B. Audio abnormal

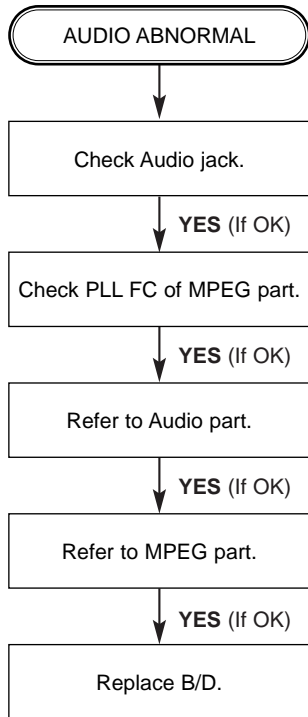

C. Video abnormal

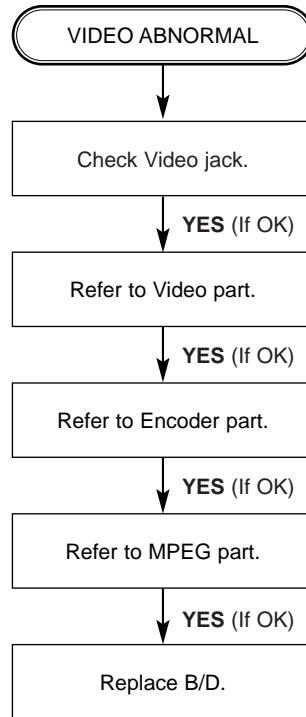

D. Open/Close abnormal

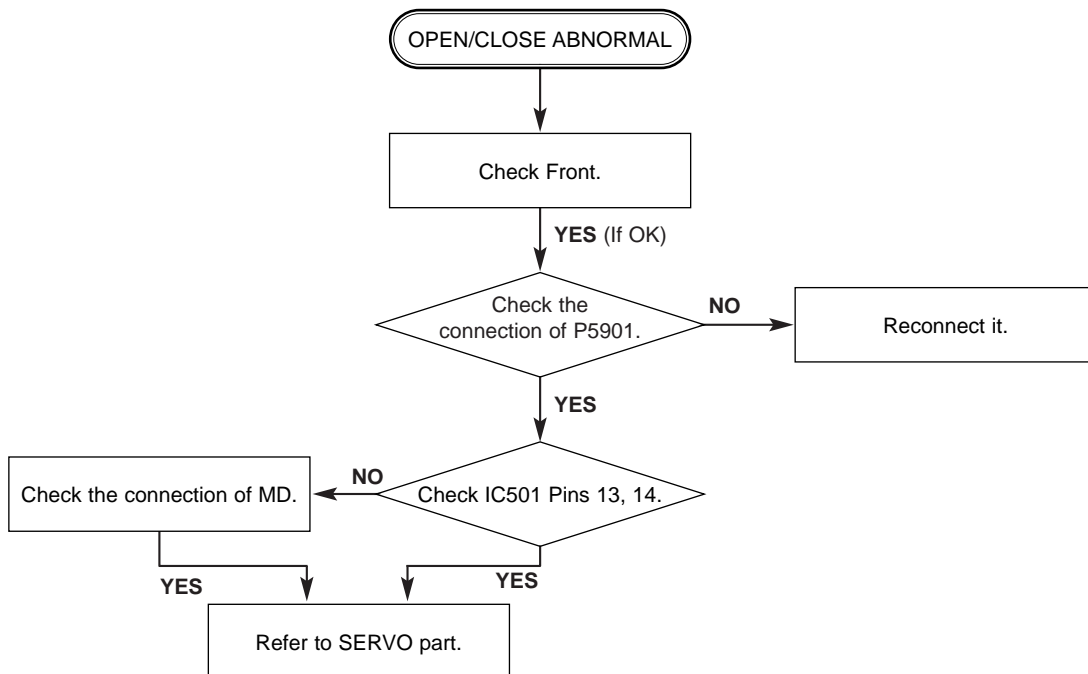

E. Picture abnormal

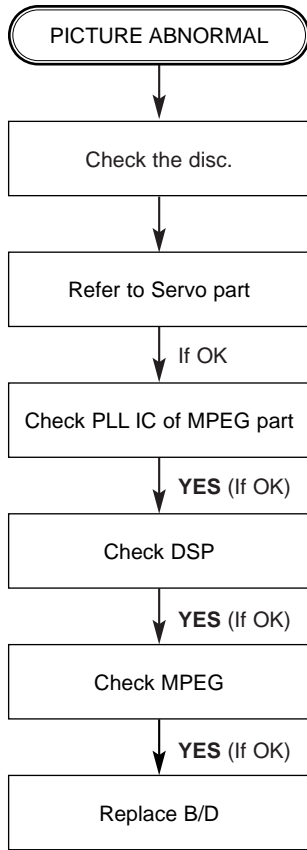

F. Disc Error

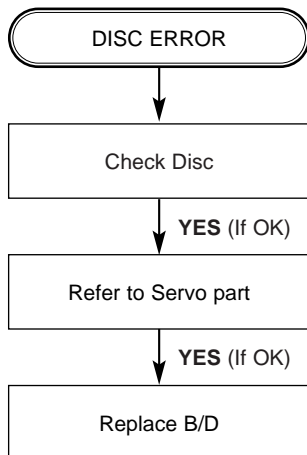

3. MPEG Circuit

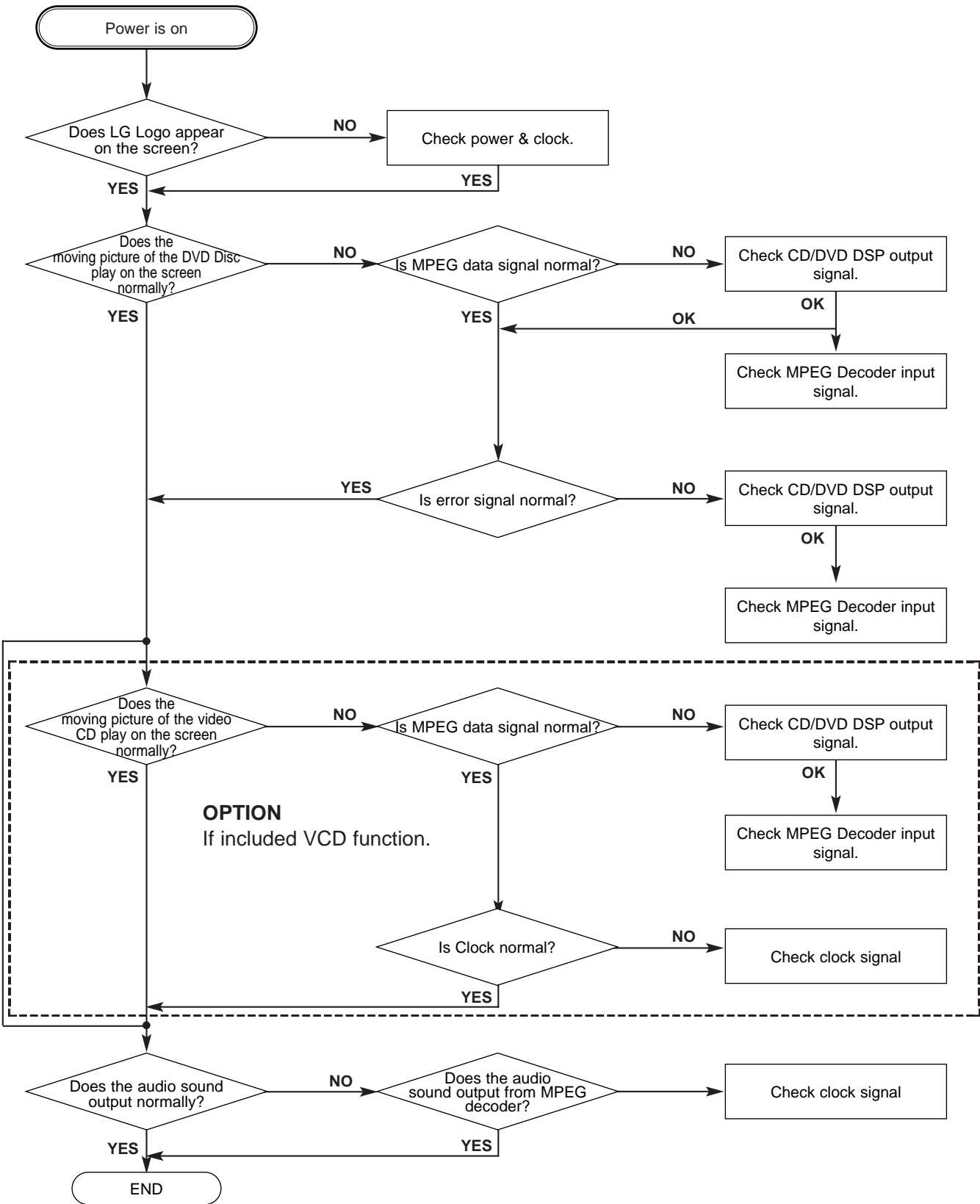

4. Front Circuit (Digitron & Key)

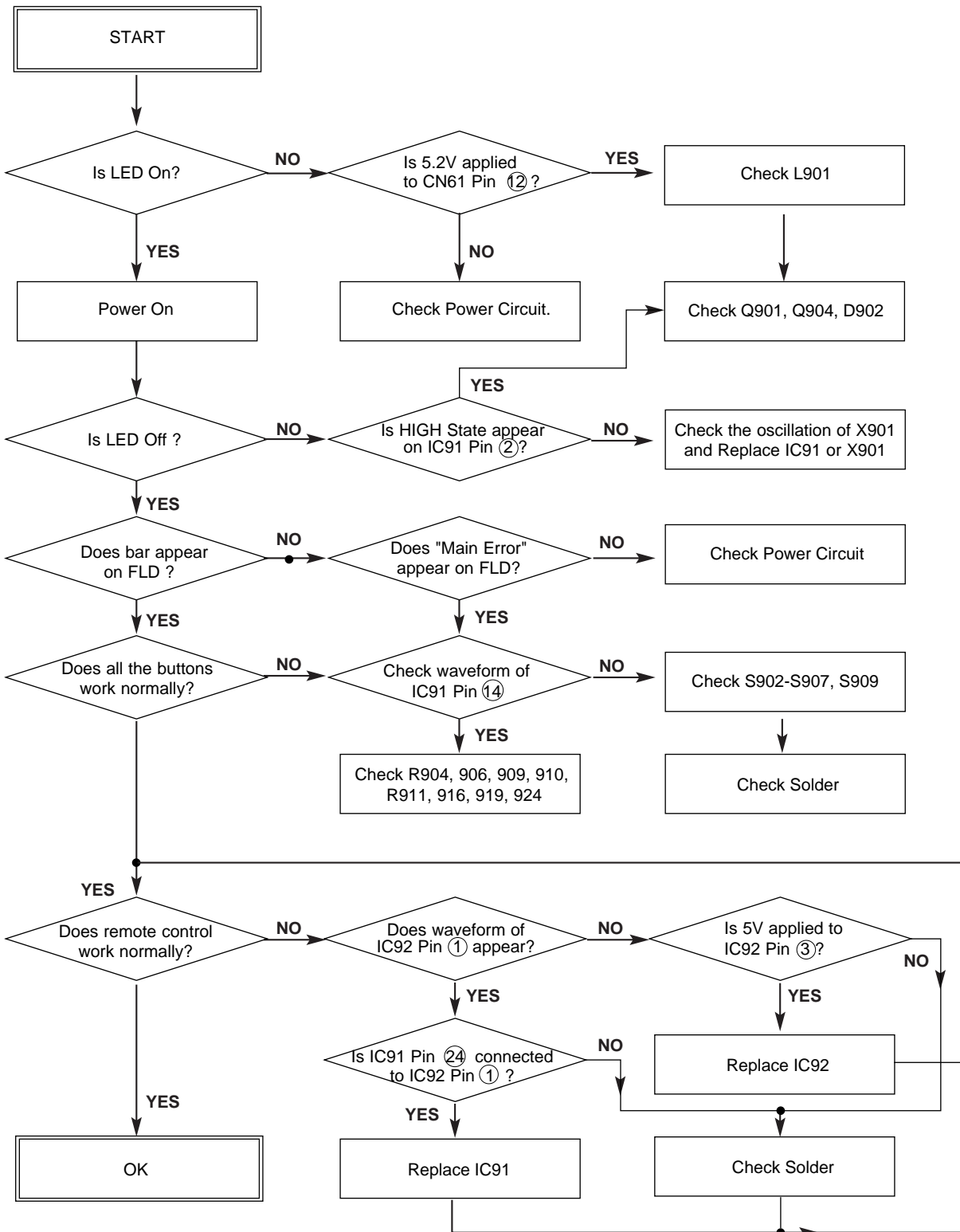

5. RF/Servo Circuit

A.

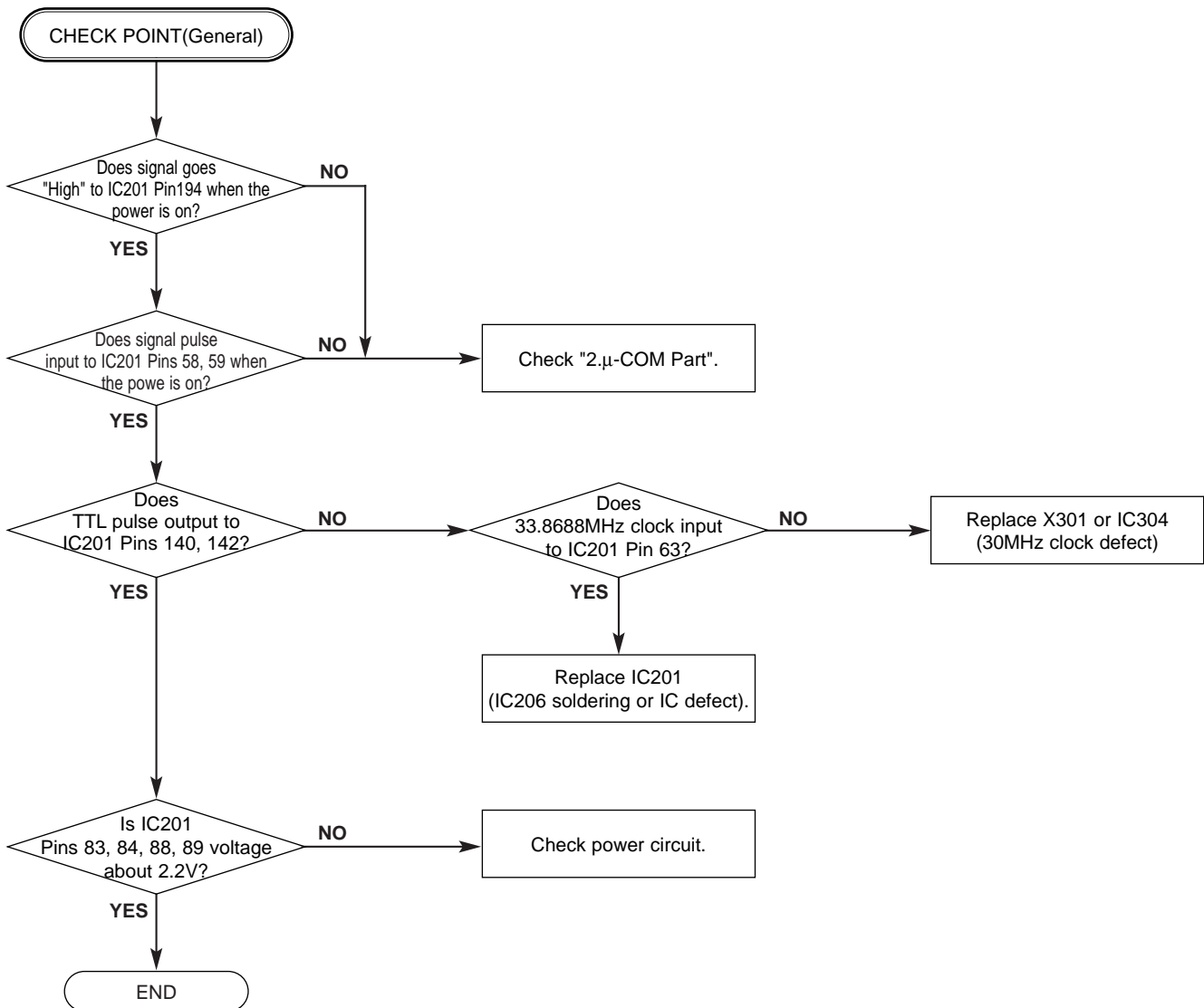

B.

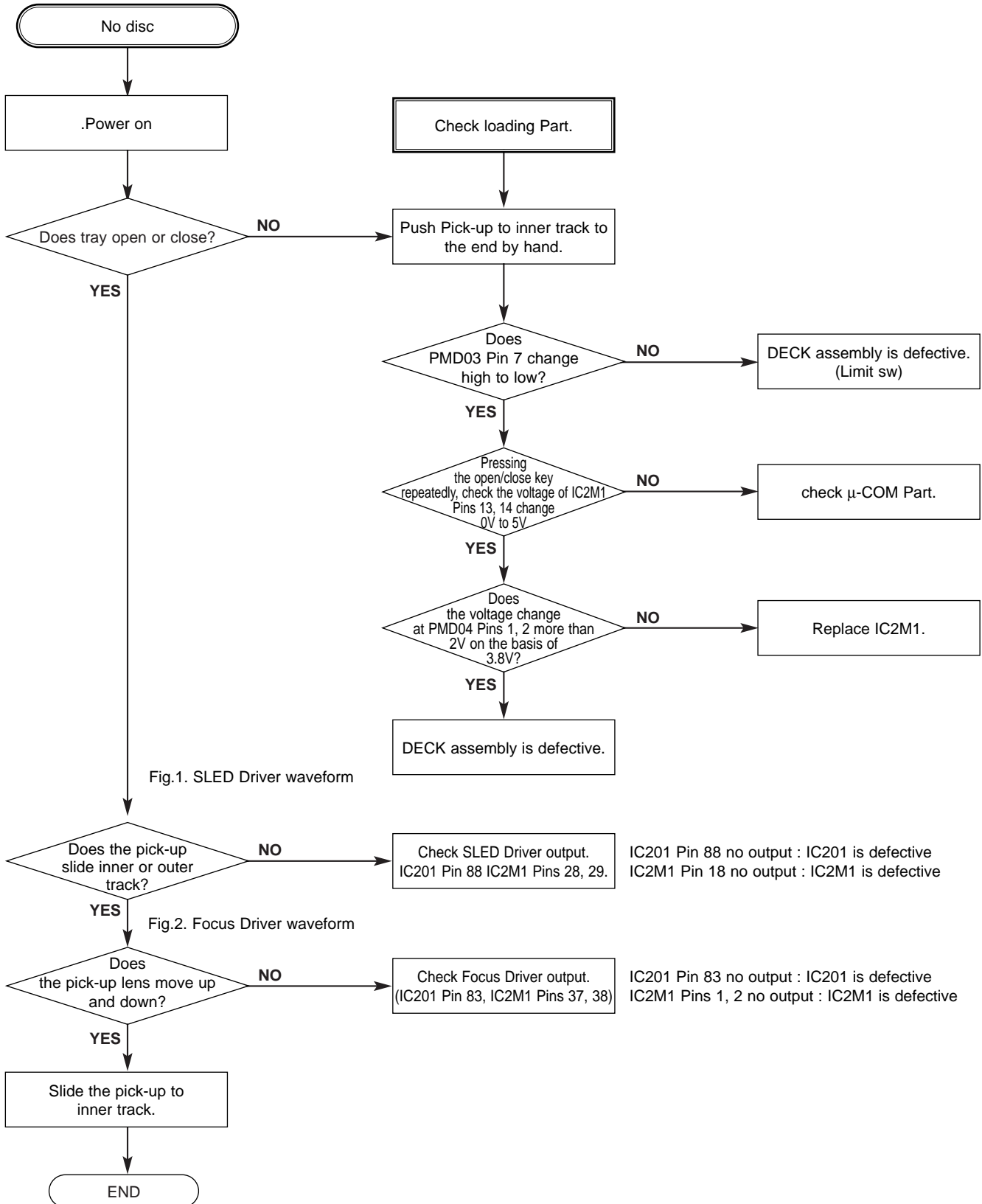

C.

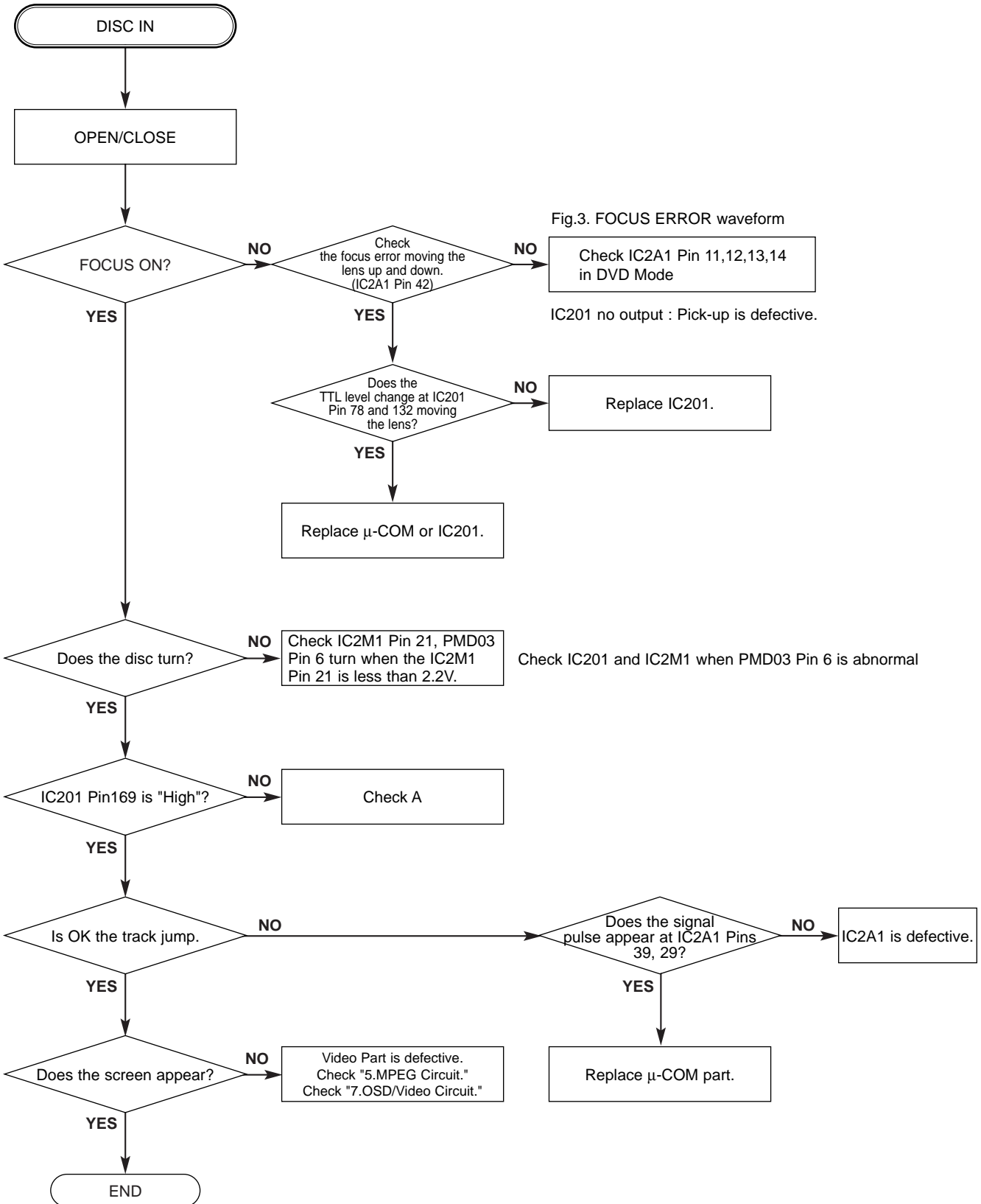

D.

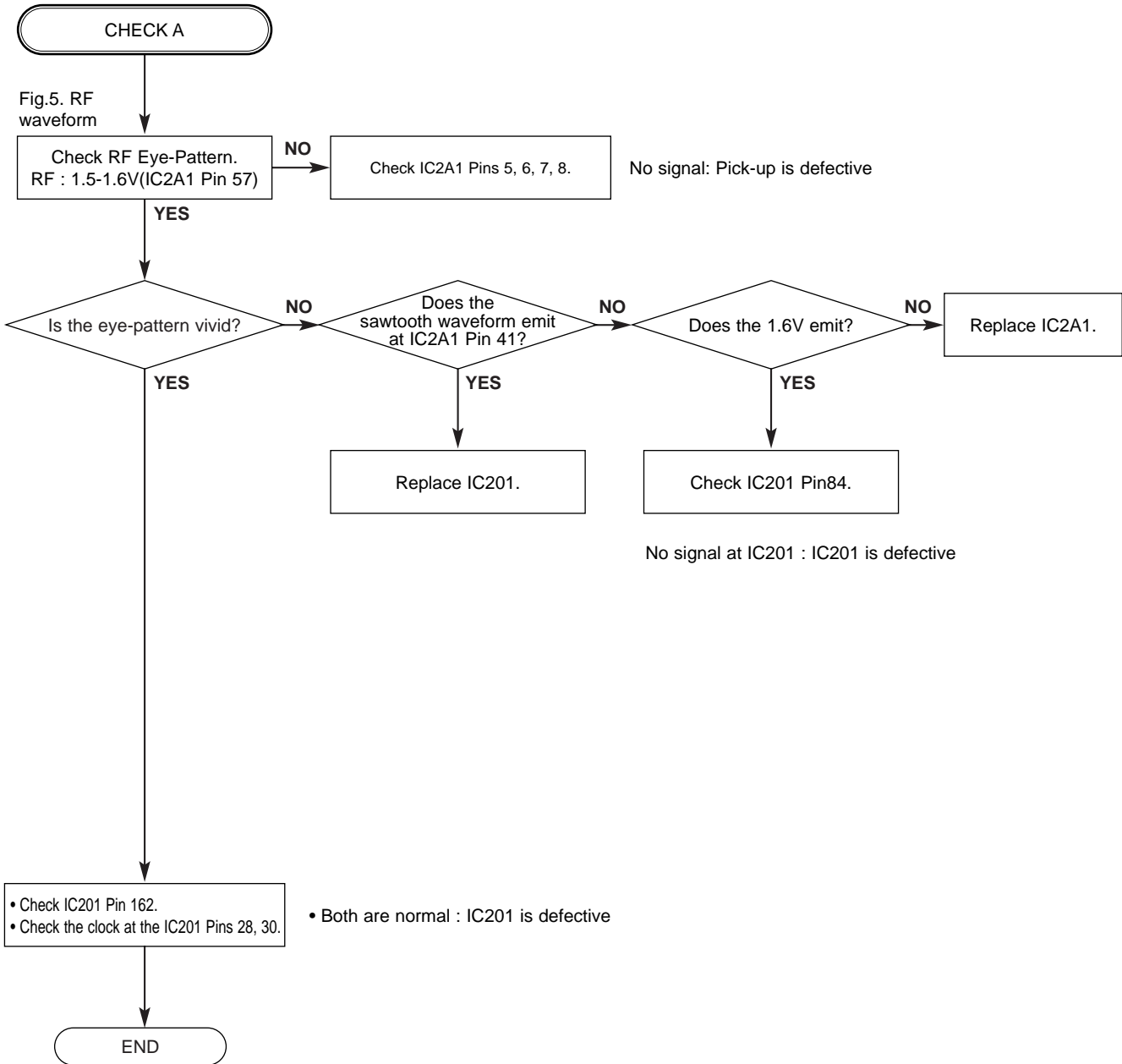

BLOCK DIAGRAM

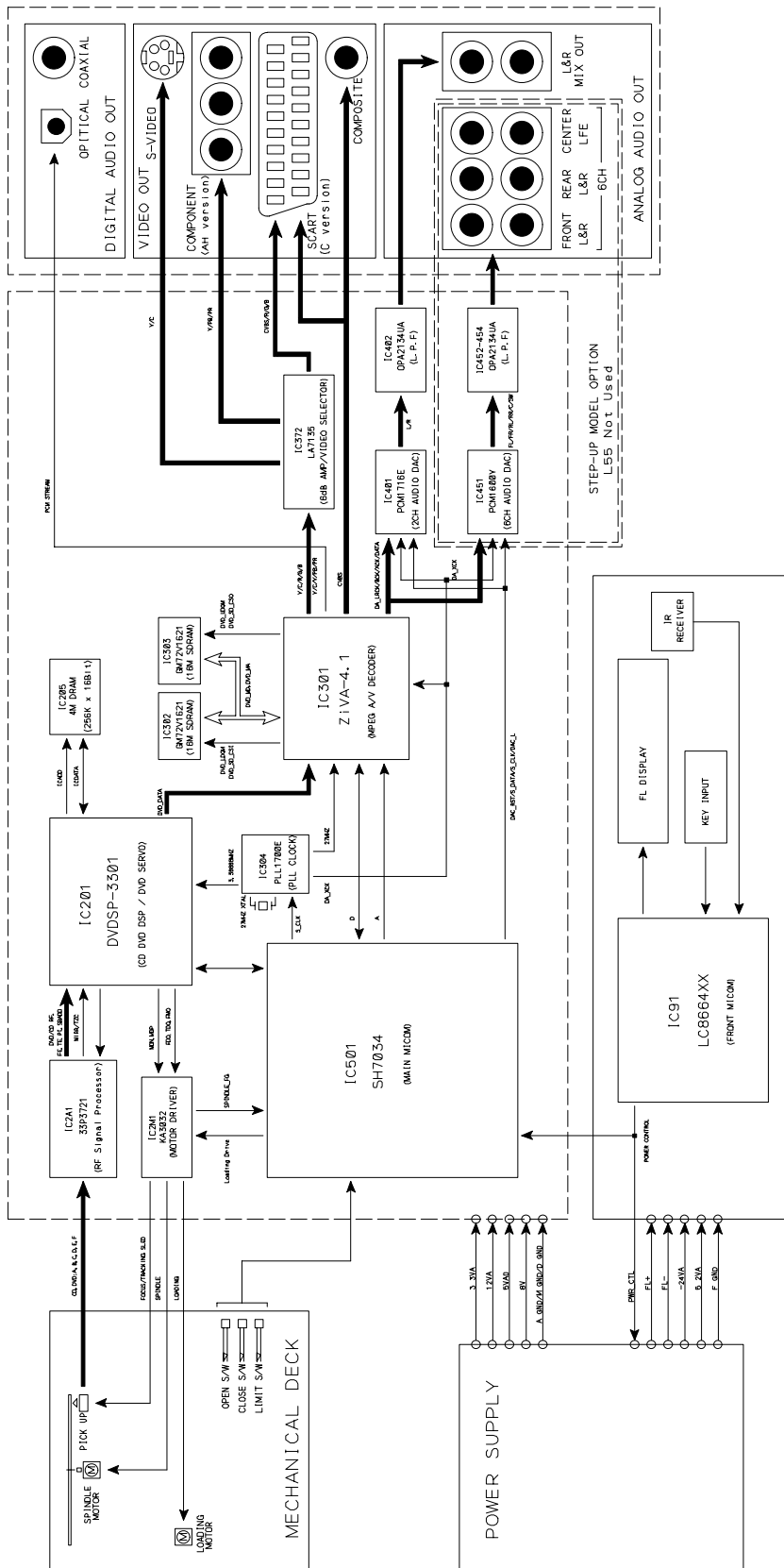

2. Power(SMPS) Block Diagram

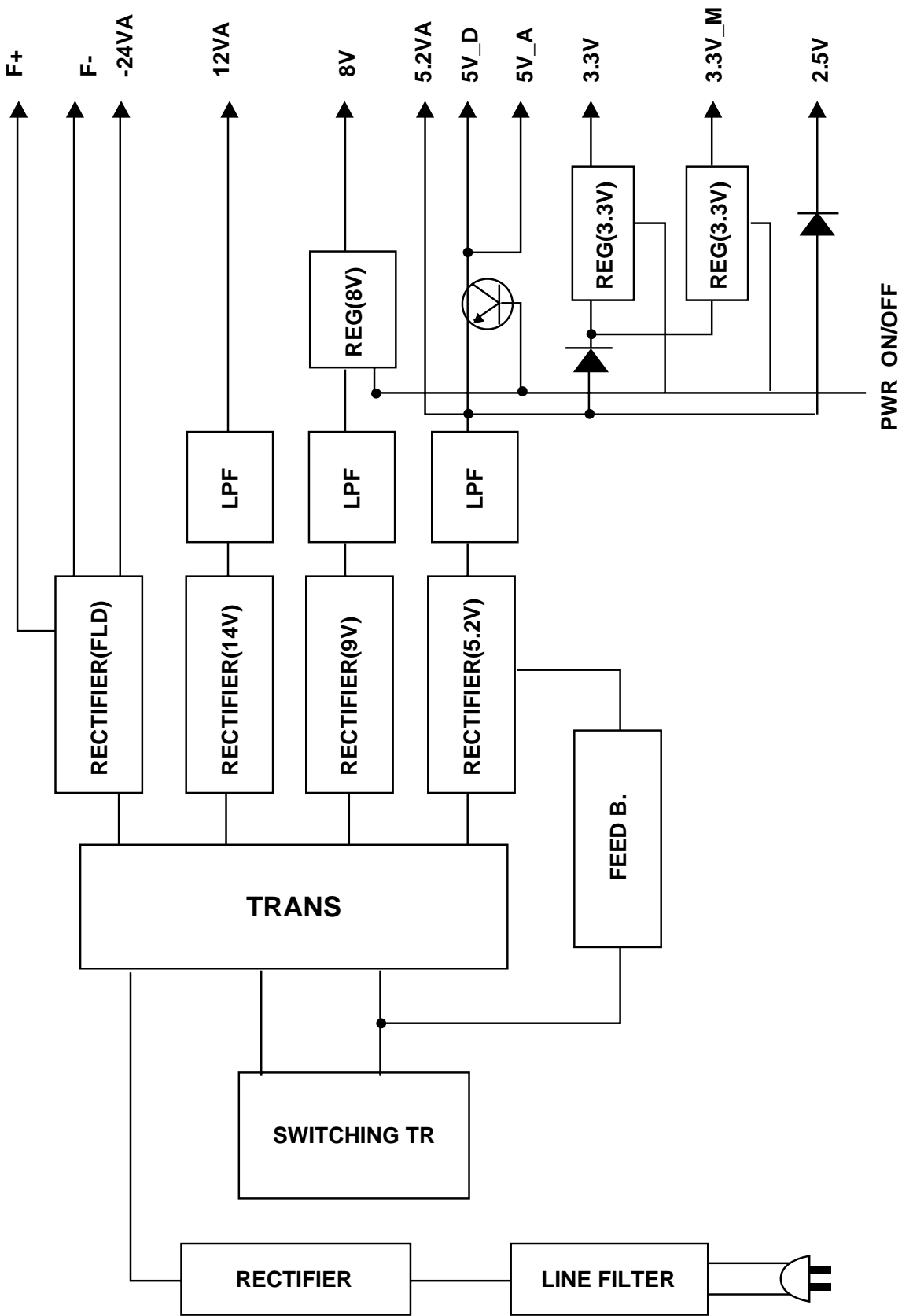

3. RF/CD DSP/DVD DSP/DVD SERVO Block Diagram

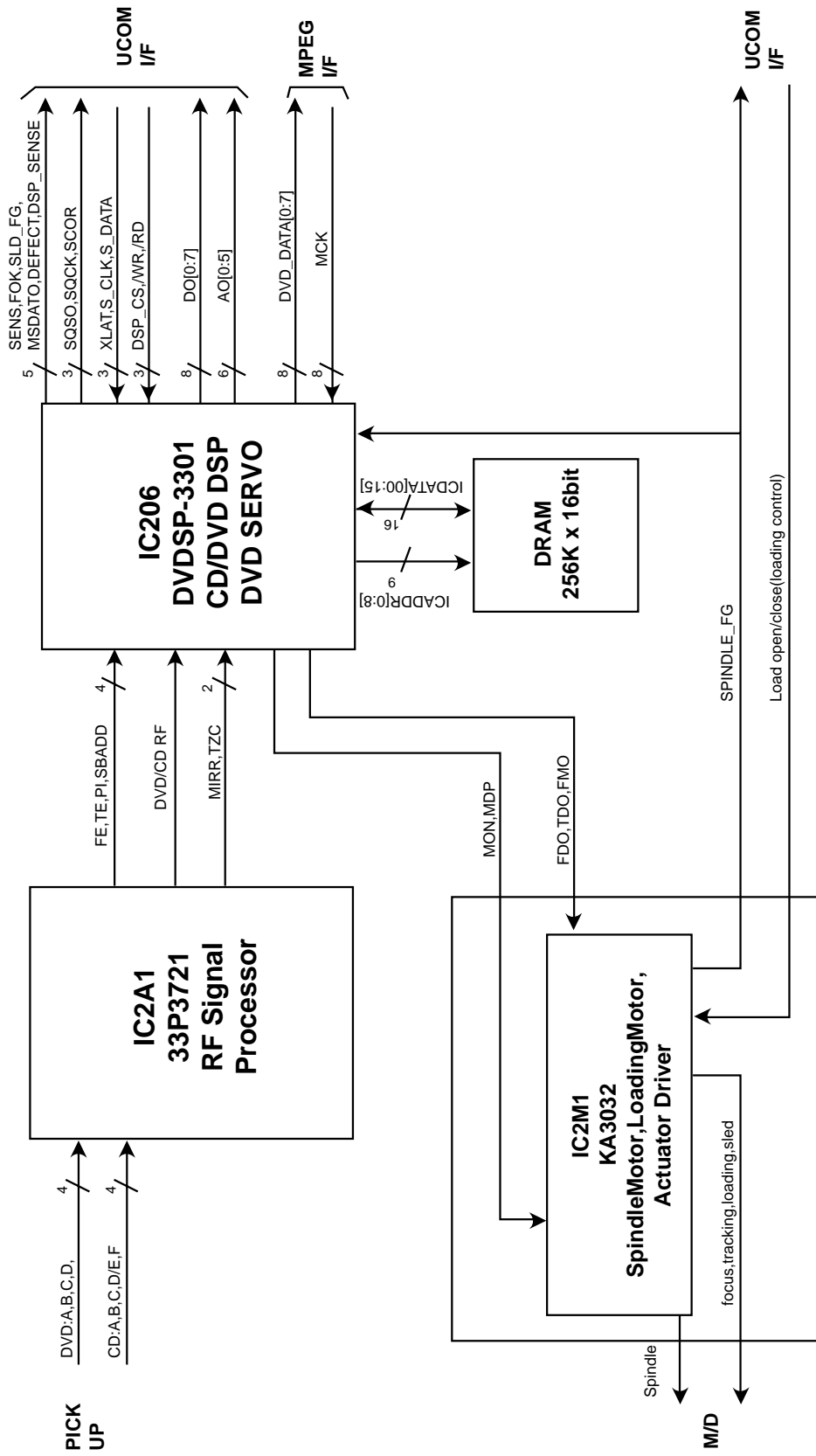

4. Audio Block Diagram

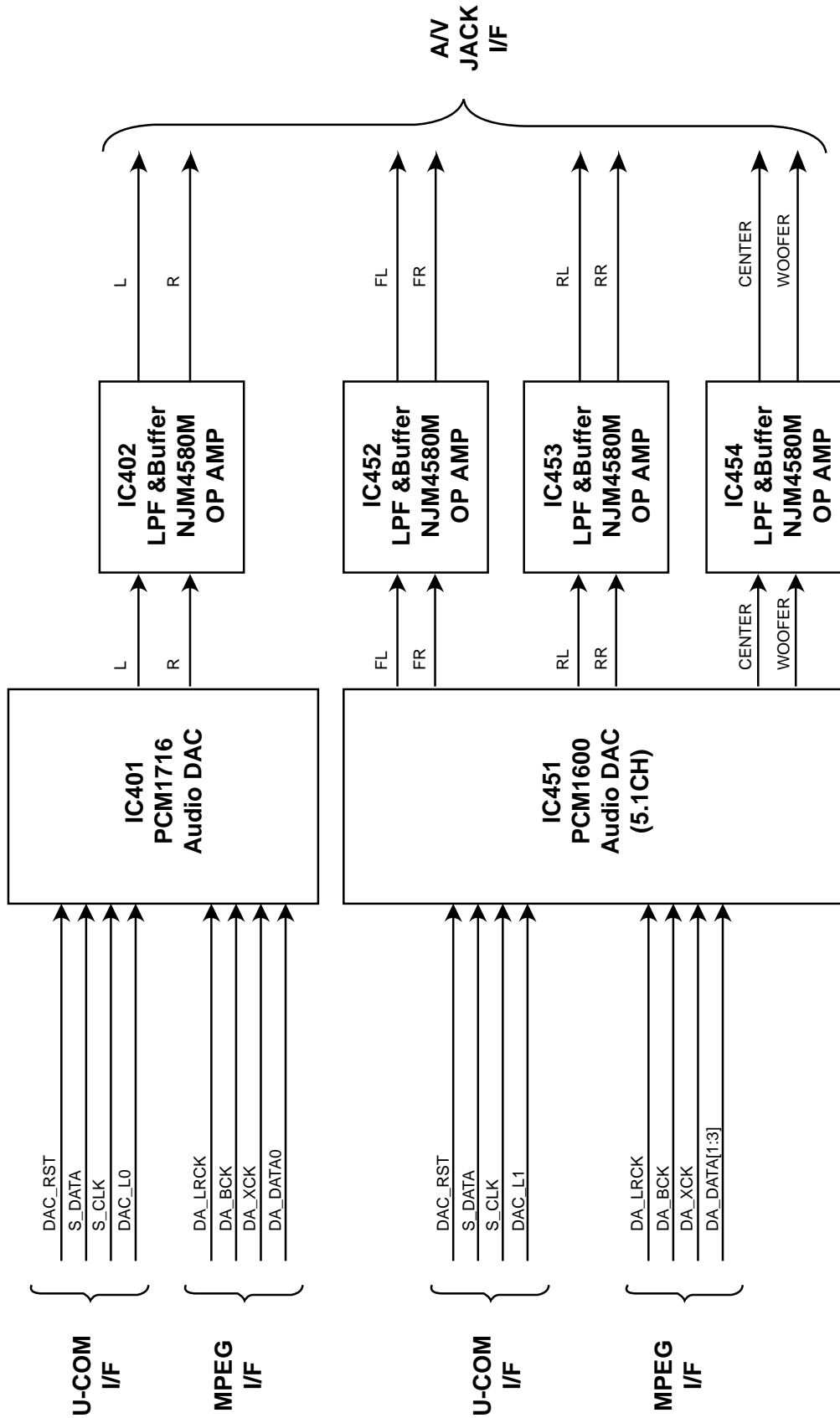

5. MPEG Block Diagram

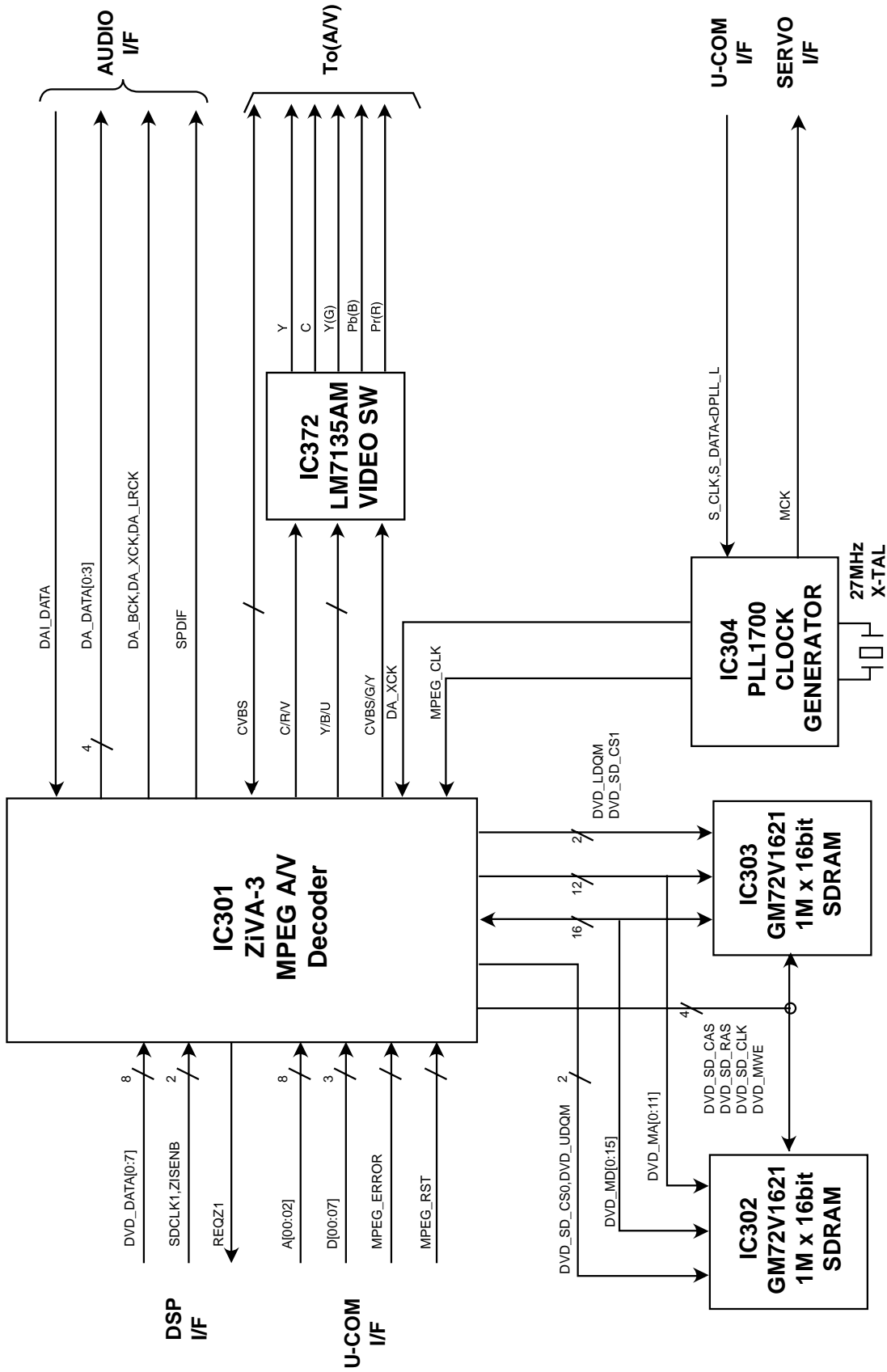

6. μ -COM Block Diagram

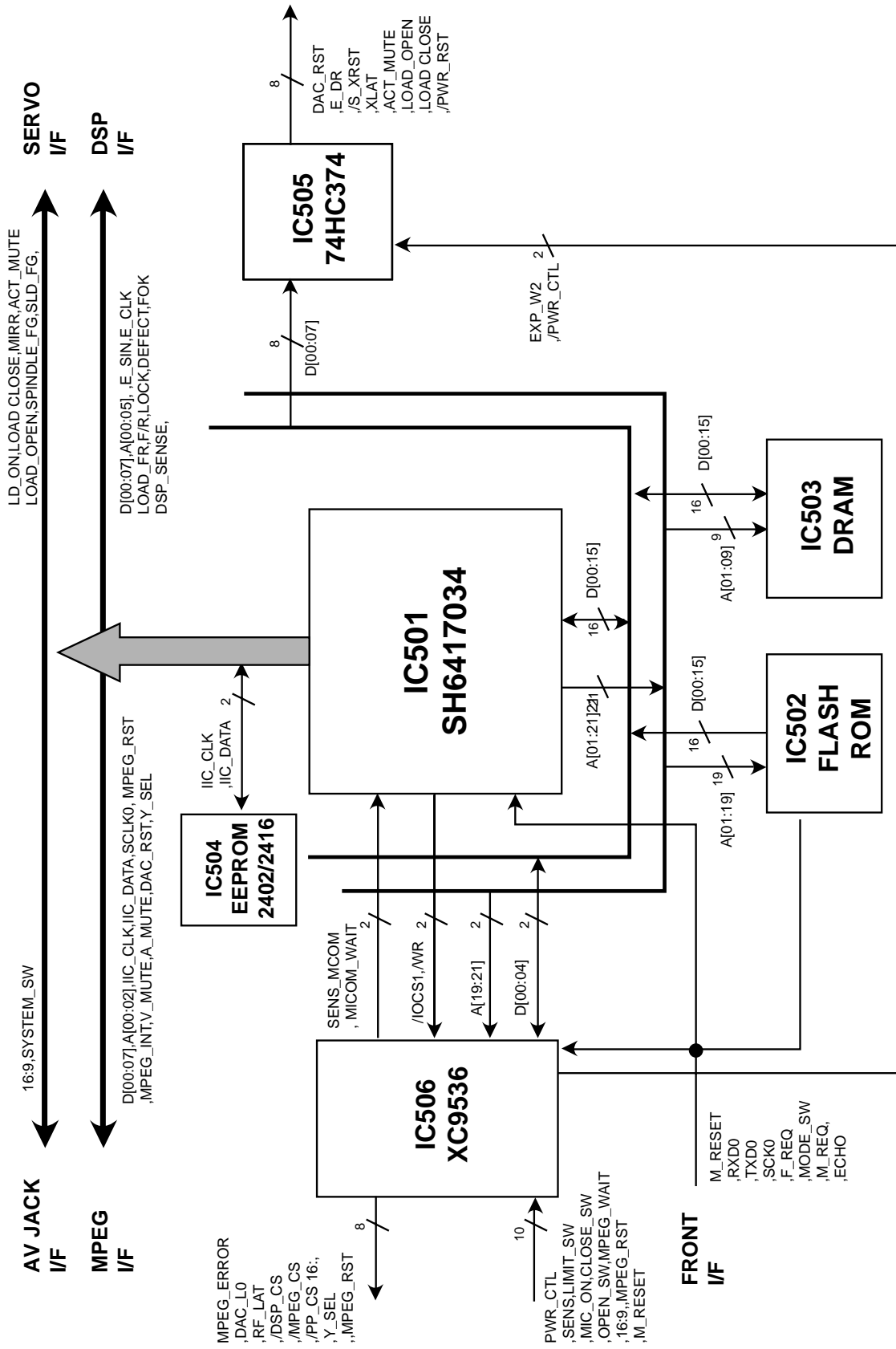

CIRCUIT DIAGRAM

1. POWER (SMPS) CIRCUIT DIAGRAM

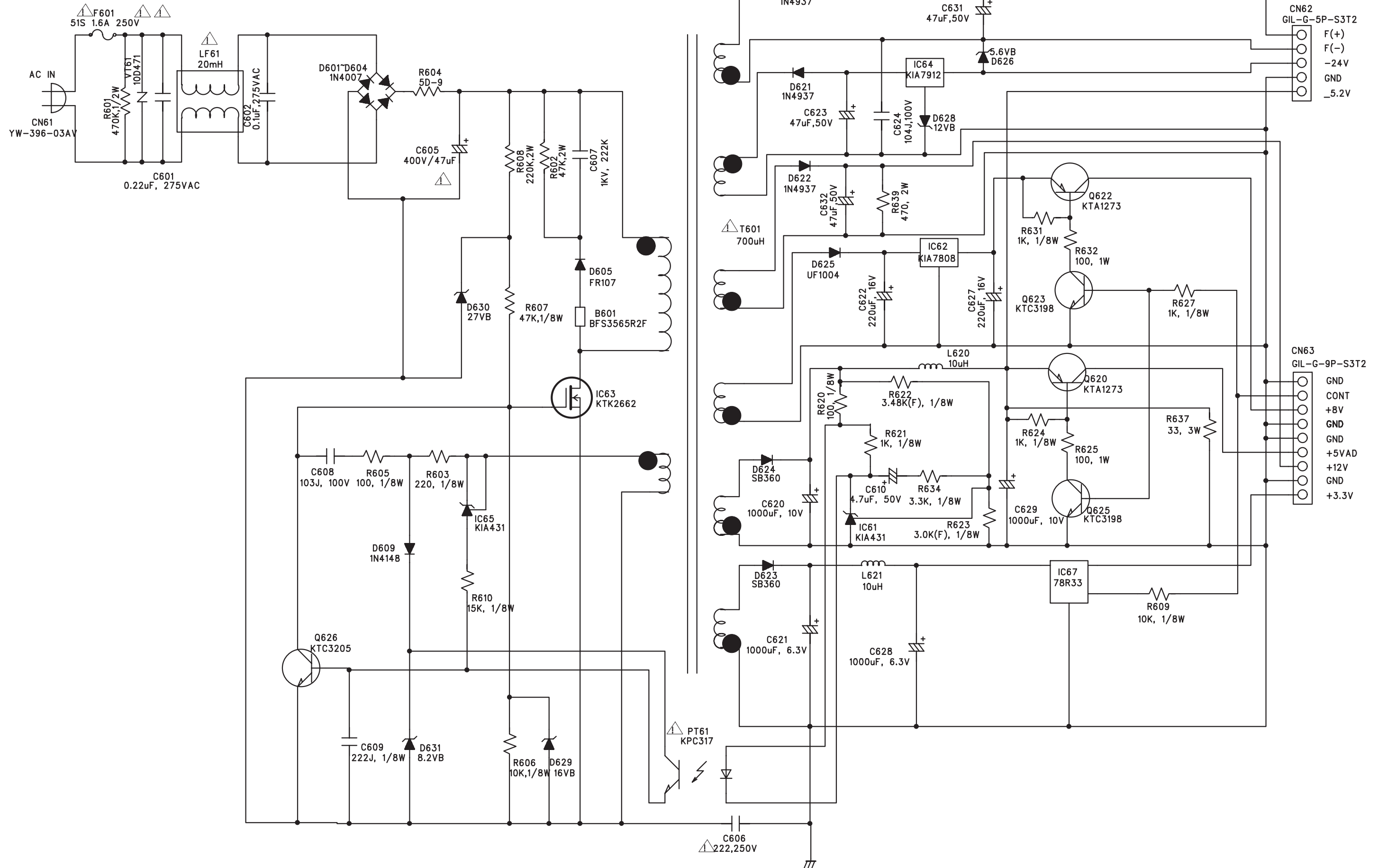

2. DVD DSP CIRCUIT DIAGRAM

LOCATION GUIDE

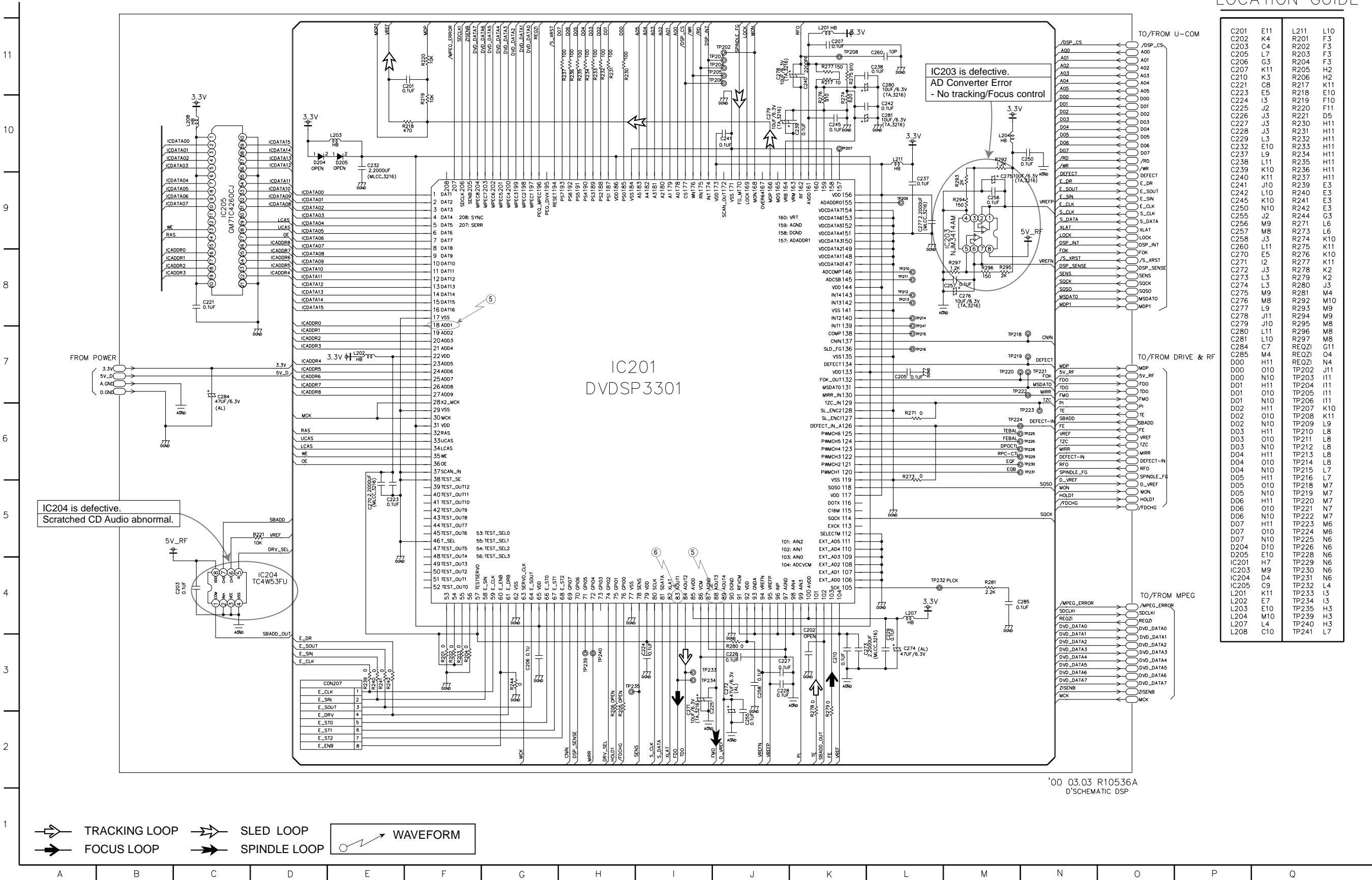

3. DRIVE & RF CIRCUIT DIAGRAM

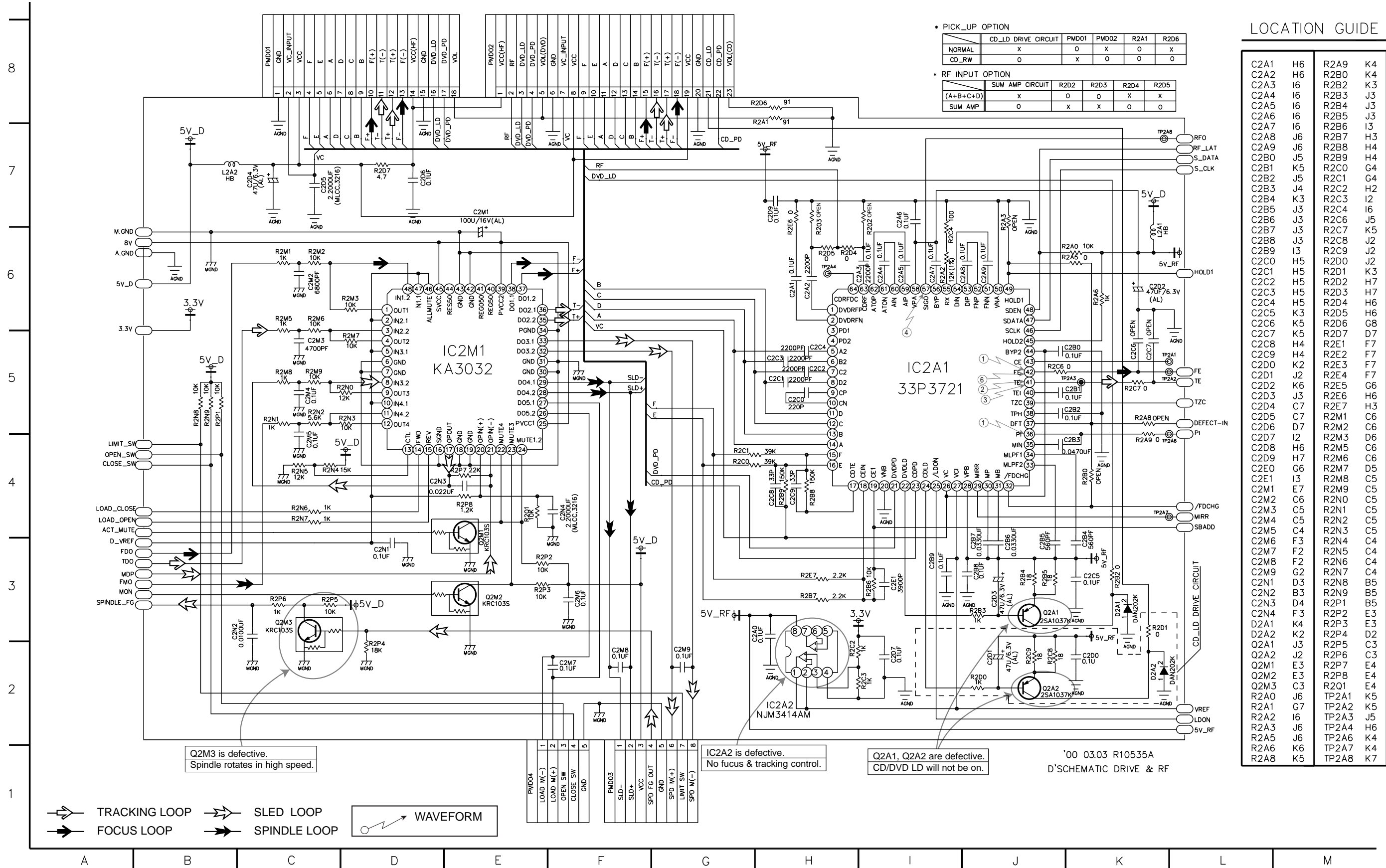

PICK_UP OPTION

	CD_LD DRIVE CIRCUIT	PMDD01	PMDD02	R2A1	R2D6
NORMAL	X	0	X	0	X
CD_RW	0	X	0	0	0

RF INPUT OPTION

	SUM AMP CIRCUIT	R2D2	R2D3	R2D4	R2D5
(A+B+C+D)	X	0	0	X	X
SUM AMP	0	X	X	0	0

LOCATION GUIDE

C2A1	H6	R2A9	K4
C2A2	H6	R2B0	K4
C2A3	I6	R2B2	K3
C2A4	I6	R2B3	J3
C2A5	I6	R2B4	J3
C2A6	I6	R2B5	J3
C2A7	I6	R2B6	I3
C2A8	J6	R2B7	H3
C2A9	J6	R2B8	H4
C2B0	J5	R2B9	H4
C2B1	K5	R2C0	G4
C2B2	J5	R2C1	G4
C2B3	J4	R2C2	H2
C2B4	K3	R2C3	I2
C2B5	J3	R2C4	I6
C2B6	J3	R2C6	J5
C2B7	J3	R2C7	K5
C2B8	J3	R2C8	J2
C2B9	I3	R2C9	J2
C2C0	H5	R2D0	J2
C2C1	H5	R2D1	K3
C2C2	H5	R2D2	H7
C2C3	H5	R2D3	H7
C2C4	H5	R2D4	H6
C2C5	K3	R2D5	H6
C2C6	K5	R2D6	G8
C2C7	K5	R2D7	D7
C2C8	H4	R2E1	F7
C2C9	H4	R2E2	F7
C2D0	K2	R2E3	F7
C2D1	J2	R2E4	F7
C2D2	K6	R2E5	G6
C2D3	J3	R2E6	H6
C2D4	C7	R2E7	H3
C2D5	C7	R2M1	C6
C2D6	D7	R2M2	C6
C2D7	I2	R2M3	D6
C2D8	H6	R2M5	C6
C2D9	H7	R2M6	C6
C2E0	G6	R2M7	D5
C2E1	I3	R2M8	C5
C2M1	E7	R2M9	C5
C2M2	C6	R2N0	C5
C2M3	C5	R2N1	C5
C2M4	C5	R2N2	C5
C2M5	C4	R2N3	C5
C2M6	F3	R2N4	C4
C2M7	F2	R2N5	C4
C2M8	F2	R2N6	C4
C2M9	G2	R2N7	C4
C2N1	D3	R2N8	B5
C2N2	B3	R2N9	B5
C2N3	D4	R2P1	B5
C2N4	F3	R2P2	E3
D2A1	K4	R2P3	E3
D2A2	K2	R2P4	D2
Q2A1	J3	R2P5	C3
Q2A2	J2	R2P6	C3
Q2M1	E3	R2P7	E4
Q2M2	E3	R2P8	E4
Q2M3	C3	R2P1	E4
R2A0	J6	TP2A1	K5
R2A1	G7	TP2A2	K5
R2A2	I6	TP2A3	J5
R2A3	J6	TP2A4	H6
R2A5	J6	TP2A6	K4
R2A6	K6	TP2A7	K4
R2A8	K5	TP2A8	K7

Q2M3 is defective.
Spindle rotates in high speed.

IC2A2 is defective.
No focus & tracking control.

Q2A1, Q2A2 are defective.
CD/DVD LD will not be on.

'00 03.03 R10535A
D'SCHEMATIC DRIVE & RF

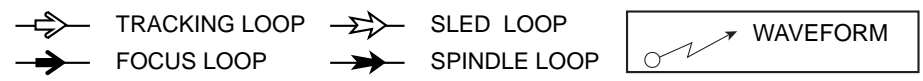

4. MPEG CIRCUIT DIAGRAM

LOCATION GUIDE

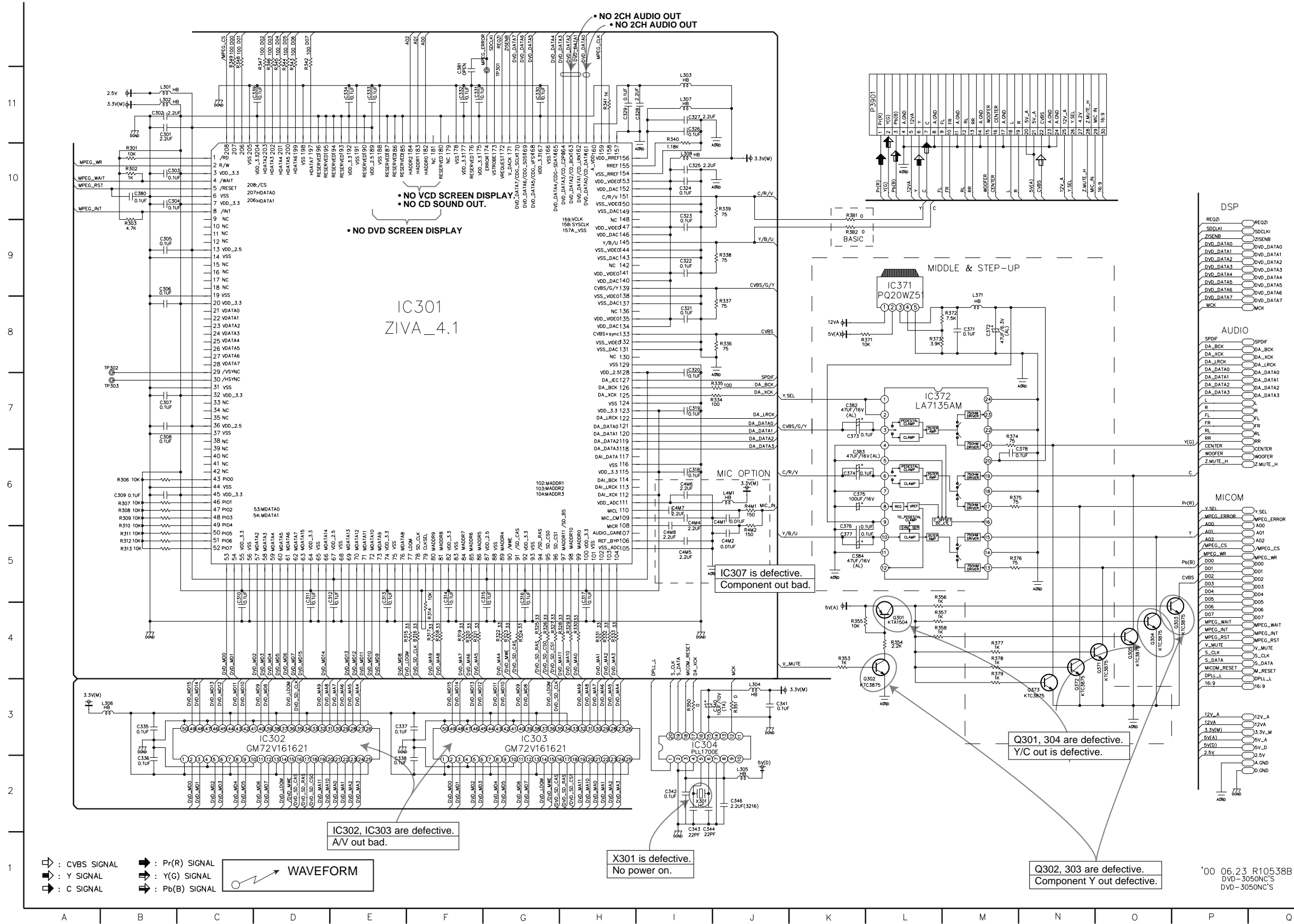

C301	B11	Q301	L4
C302	B11	Q302	K3
C303	B10	Q303	P4
C304	B10	Q304	O4
C305	B9	Q305	O4
C306	B9	Q371	O4
C307	B7	Q372	N3
C308	B7	Q373	N3
C309	B6	R301	B10
C310	C4	R302	B10
C311	D4	R303	B9
C312	E4	R306	B6
C313	E4	R307	B6
C314	F4	R308	B6
C315	G4	R309	B6
C316	G4	R310	B5
C317	H4	R311	B5
C318	I6	R312	B5
C319	I7	R313	B5
C320	I8	R314	F4
C321	I8	R315	F4
C322	I9	R316	F4
C323	I10	R317	F4
C324	I10	R318	F4
C325	I10	R319	F4
C326	I11	R320	F4
C327	I11	R321	F4
C328	I11	R322	G4
C329	H11	R323	G4
C330	G11	R324	G4
C331	F11	R325	G4
C332	F11	R326	G4
C333	E11	R327	G4
C334	E11	R328	H4
C335	B5	R329	H4
C336	B2	R330	H4
C337	E3	R331	H4
C338	E2	R332	H4
C339	D11	R333	H4
C340	J3	R334	I7
C341	J3	R335	I7
C342	I2	R336	J8
C343	I2	R337	J8
C344	I2	R338	J9
C346	J2	R339	J10
C371	M8	R340	I11
C372	M8	R341	H11
C373	K7	R342	D11
C374	K6	R343	D11
C375	K6	R344	D11
C376	K5	R345	D11
C377	K5	R346	D11
C378	M6	R347	D11
C380	B10	R348	C11
C381	F11	R349	C11
C382	K7	R350	J3
C383	K6	R351	J3
C384	K5	R353	K4
C3K1	L2	R354	L4
C4M1	J6	R355	K4
C4M2	J5	R356	L5
C4M4	I6	R357	L4
C4M5	I5	R358	L4
C4M6	I6	R371	K8
C4M7	I6	R372	M8
C4M8	I5	R373	L8
IC301	E8	R374	M7
IC302	D3	R375	M6
IC303	G3	R376	M5
IC304	I3	R377	M4
IC371	L9	R378	M4
IC372	L7	R379	M4
IC3K1	K3	R381	K10
L301	B11	R382	K9
L302	B11	R3K1	K3
L303	I11	R3K2	L2
L304	J3	R4M1	J6
L305	J2	R4M2	J5
L306	B3	REOZ1	G12
L307	I11	REOZ1	O9
L308	I10	REOZ1	P9
L371	M8	TP301	G11
L4M1	J6	TP302	B8
P3901	L10	TP303	B7
Pb(B)	L11		
Pb(B)	P5		

'00 06.23 R10538B
DVD-3050NC'S
DVD-3050NC'S

4-1. WAVEFORMS (RF/SERVO)

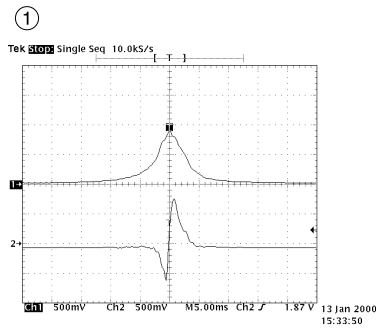

IC2A1 Pin 42, Focus Error
IC2A1 Pin 36, Pi



IC2A1 Pin 57,
RF

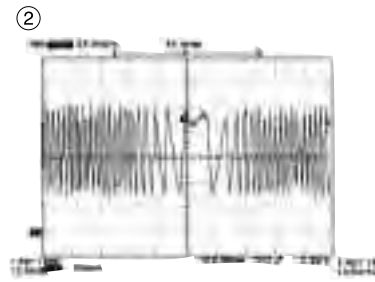

IC2A1 Pin 41
Tracking Error

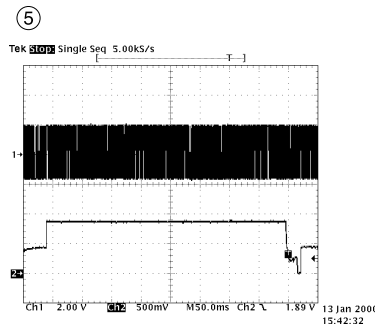

IC201 Pin 88, SLED Drive(FMO)
IC201 Pin 18, SLED FG

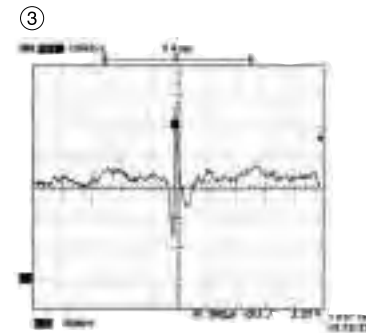

IC2A1 Pin 41
VBR TRACKING Error

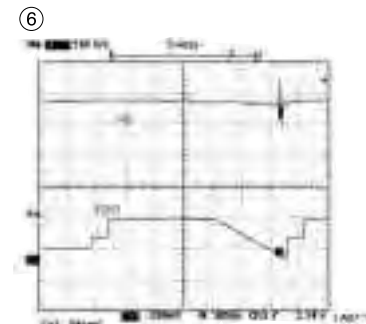

IC2A1 Pin42, Focus Error(in Focus Search)
IC201 Pin 83, Focus Drive(FDO)

(VIDEO ENCODER)

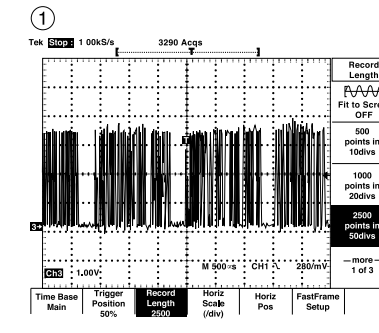

IC305 Pins 9~16, MPEG Data

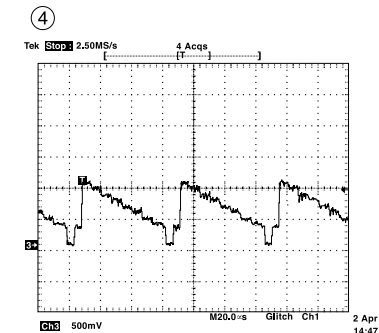

IC305 Pin 27, Luminance

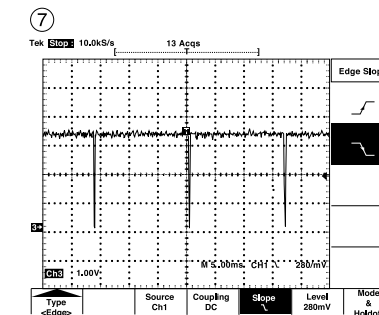

IC305 Pin 7, Vertical SYNC

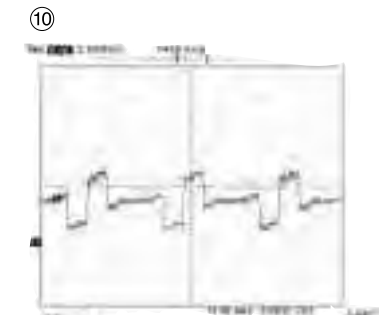

IC305 Pin 23 Component Pr

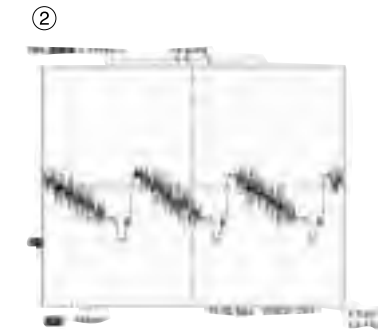

IC305 Pin 30, Composite

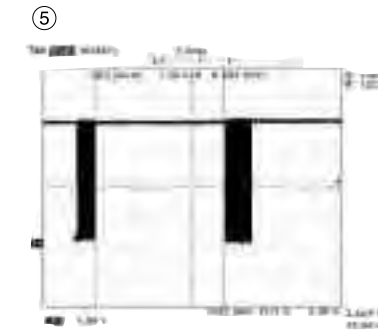

IC305 Pins 40, 41 SDA/SCL

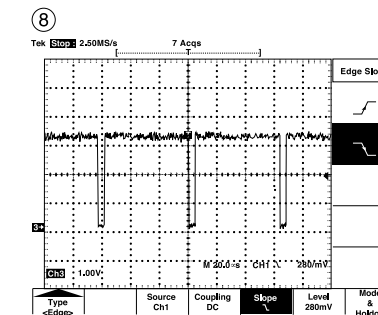

IC305 Pin 8 Horizontal SYNC

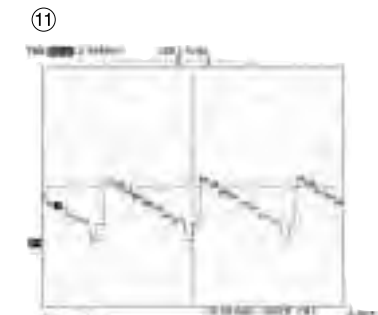

IC305 Pin 27 Component Y

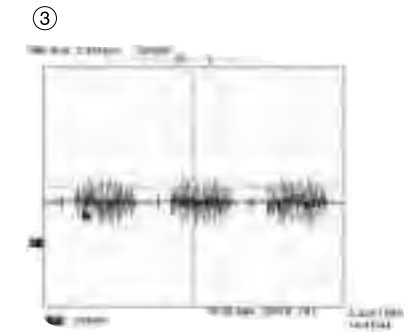

IC305 Pin 24, Chrominance

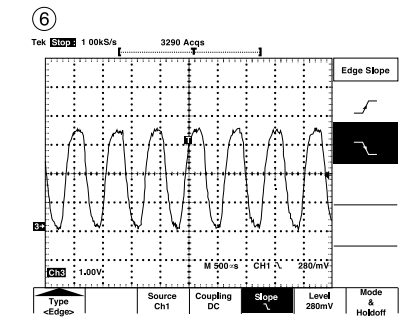

IC305 Pin 4, MPEG Clock(27MHz)

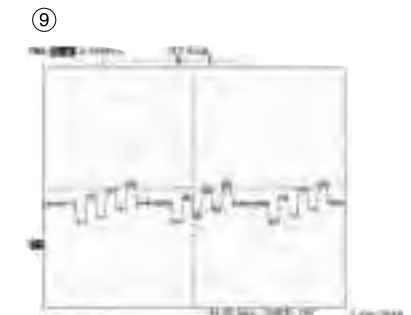

IC305 Pin 29 Component Pb

5. Audio DM & 5.1CH Circuit Diagram

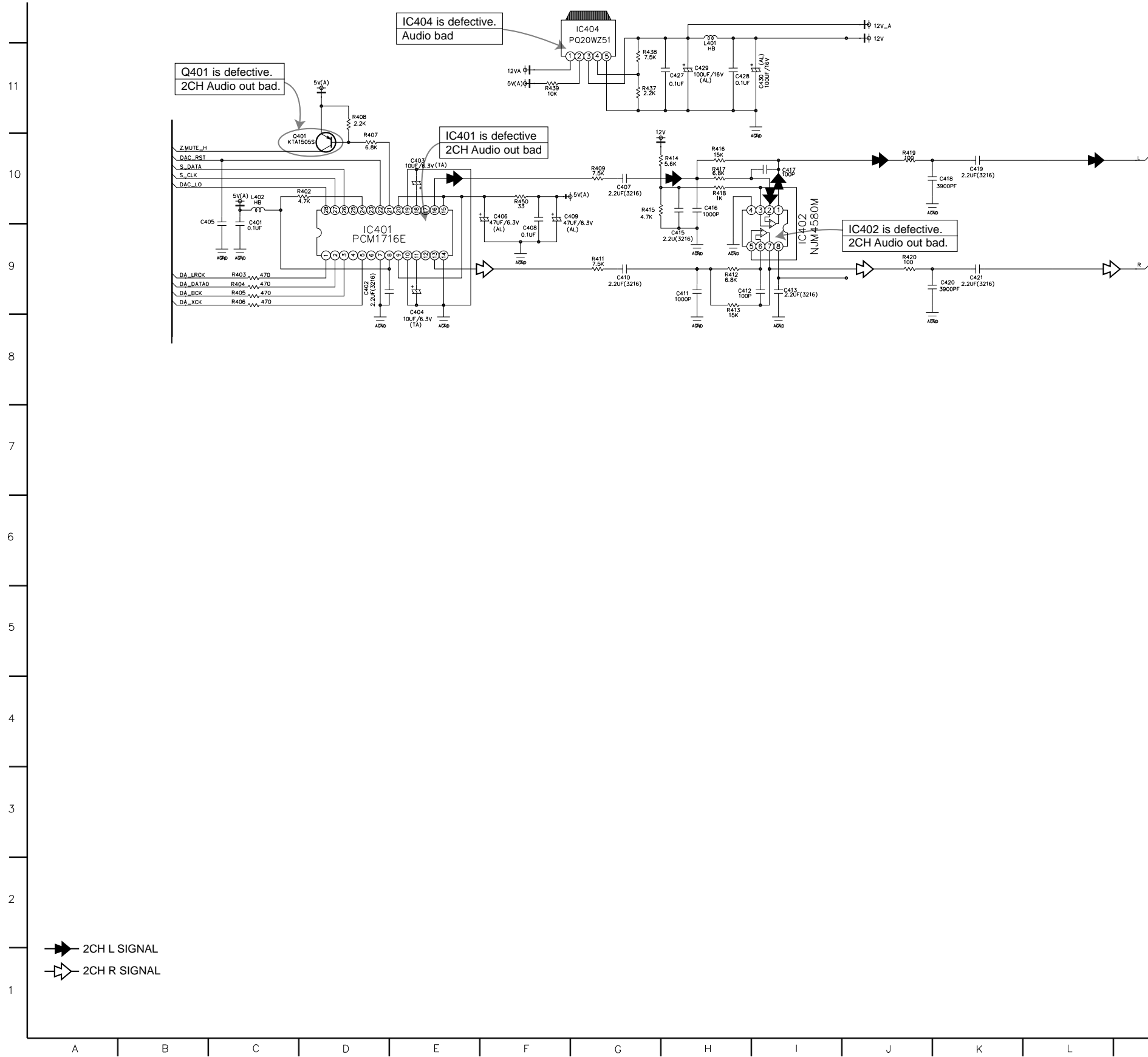

LOCATION GUIDE

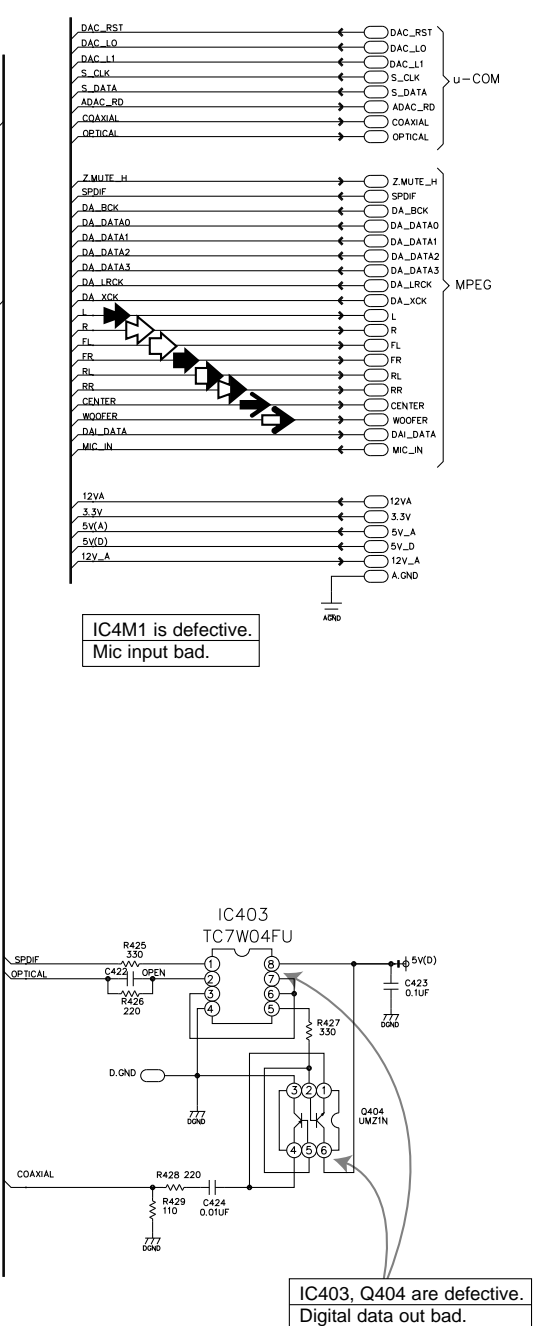

C401	C9	Q401	C10
C402	D9	Q404	O4
C403	E10	R402	C10
C404	E9	R403	C9
C405	B10	R404	C9
C406	F10	R405	C9
C407	G10	R406	C9
C408	F9	R407	D10
C409	F10	R408	D11
C410	G9	R409	G10
C411	H9	R411	C9
C412	H9	R412	H9
C413	I9	R413	H9
C415	H9	R414	H10
C416	H10	R415	G10
C417	I10	R416	H10
C418	K10	R417	H10
C419	K10	R418	H10
C420	K9	R419	J10
C421	K9	R420	J9
C422	N5	R425	N5
C423	P4	R426	N4
C424	N3	R427	O4
C427	H11	R428	N3
C428	H11	R429	N3
C429	H11	R437	G11
C430	I11	R438	G11
C450	B6	R439	F11
C451	C6	R450	F10
C452	E7	R451	C4
C453	F6	R452	C4
C454	D4	R453	C4
C455	G8	R454	C4
C456	H7	R455	C3
C457	H7	R456	C3
C458	I8	R457	G8
C459	K8	R458	H8
C460	K8	R459	G7
C461	G7	R460	H8
C462	H7	R461	H8
C463	H7	R462	H8
C464	I7	R463	J8
C465	K7	R465	K8
C466	K7	R466	L8
C467	G6	R467	G7
C468	H5	R468	H7
C469	H5	R469	H6
C470	I6	R470	J7
C471	K6	R472	L7
C472	K6	R473	L7
C473	G5	R474	G6
C474	H4	R475	H6
C475	H4	R476	G5
C476	I4	R477	H6
C478	K5	R478	H6
C479	K5	R479	H6
C480	G3	R480	J6
C481	H3	R482	L6
C482	H3	R483	L6
C483	I4	R484	G5
C484	K4	R485	H5
C485	K4	R486	H4
C486	G2	R487	J5
C487	H2	R489	L5
C488	H2	R490	L5
C490	K2	R491	G4
C491	K2	R492	H4
C492	I2	R493	G3
C4M1	O6	R494	H4
C4M2	O5	R495	H4
C4M3	O6	R496	H4
C4M4	O6	R497	J4
IC401	D9	R499	L4
IC402	I9	R4A1	L4
IC403	N5	R4A2	G3
IC404	G12	R4A3	H3
IC451	D6	R4A4	H2
IC452	I7	R4A6	J3
IC453	I5	R4A8	L3
IC454	I3	R4A9	L2
IC4M1	N6	R4M1	N6
L401	H11	R4M2	N6
L402	C10	R4M3	N6
L451	C5	R4M4	N5
L452	C7	R4M5	O6
L4M1	O6	R4M6	O5

'00 01.17 R10539B
DVD3351ND'S

6. μ -com/ Expander

LOCATION GUIDE

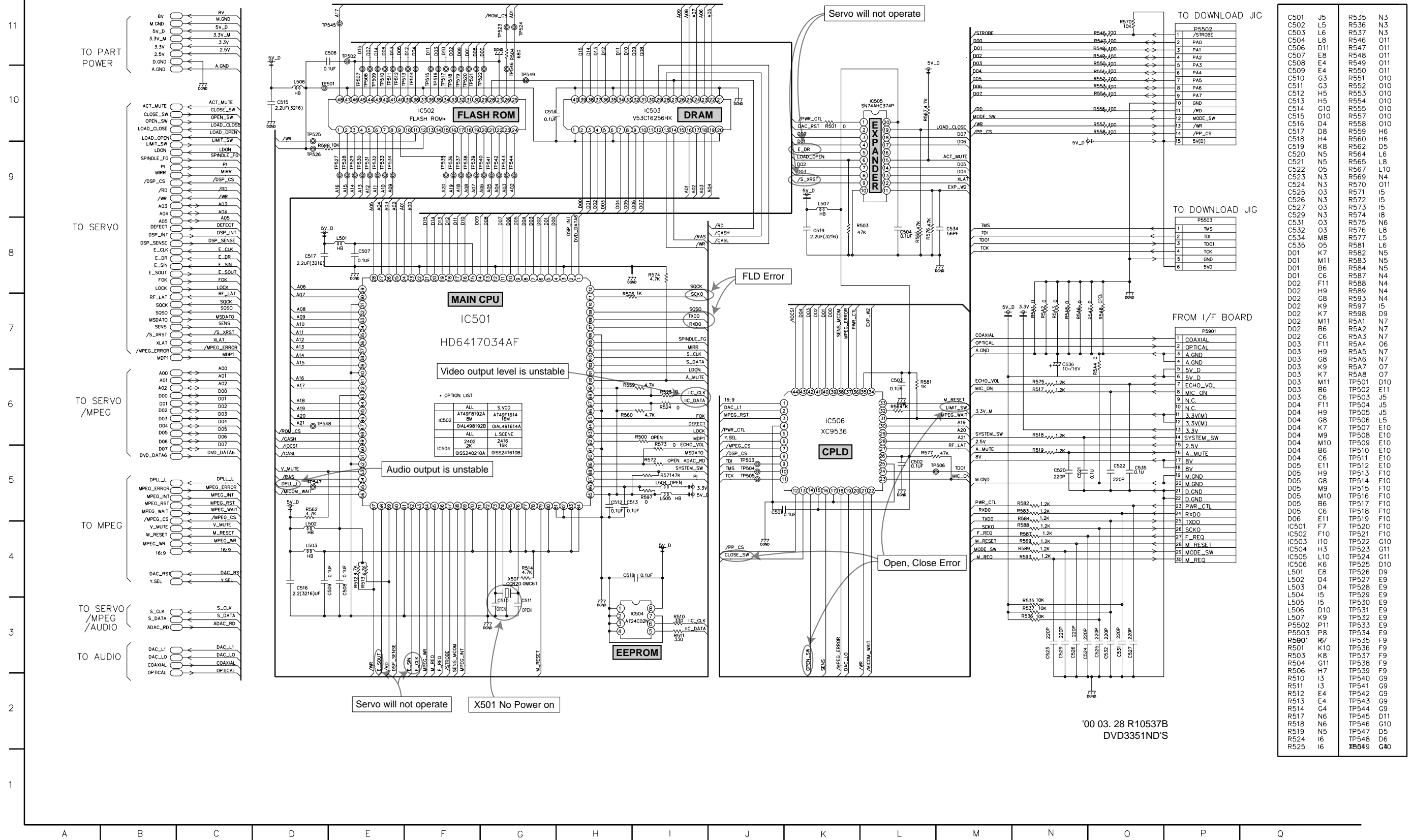

7. DIGITRON & KEY CIRCUIT DIAGRAM

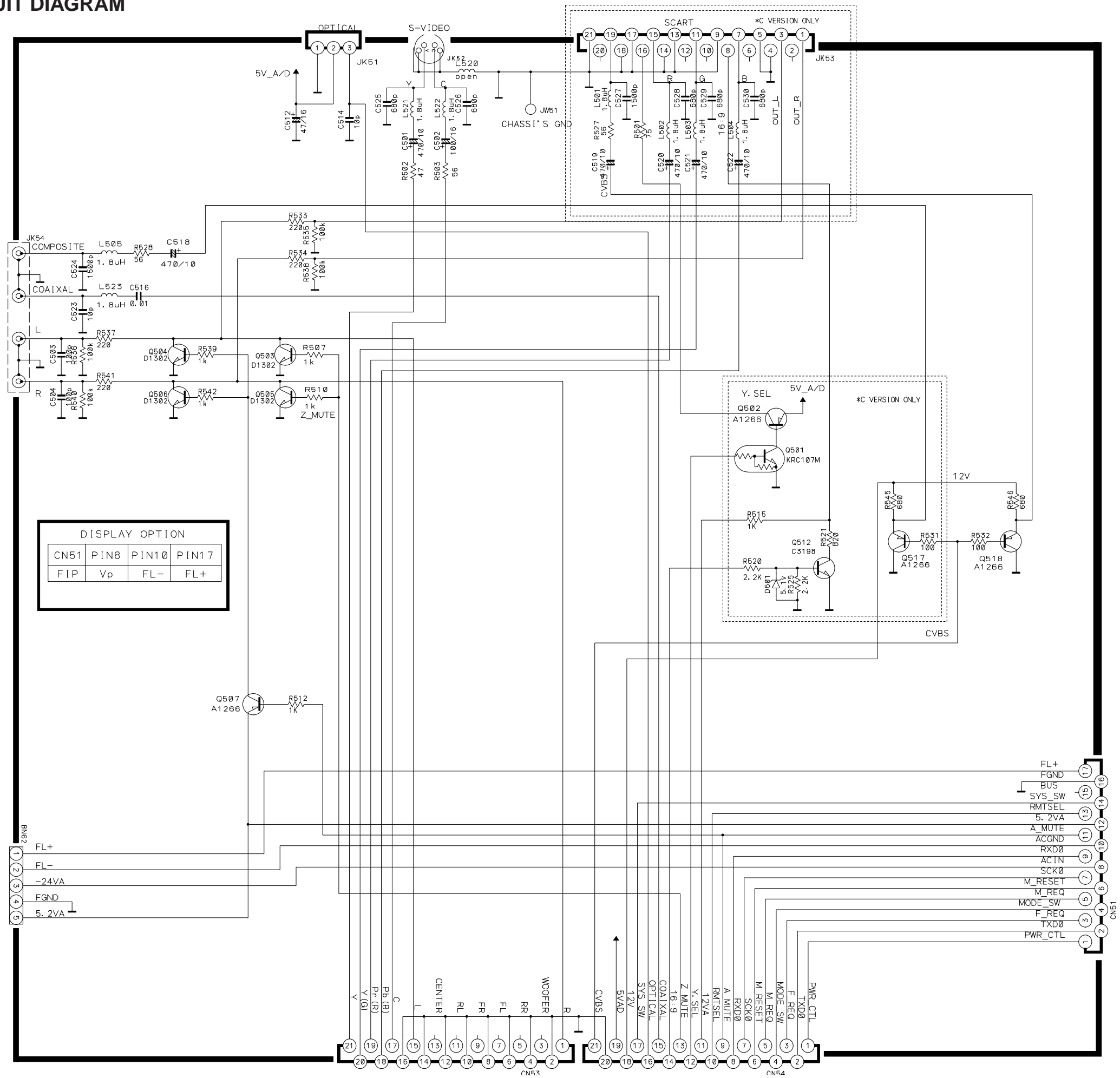

8. JACK CIRCUIT DIAGRAM

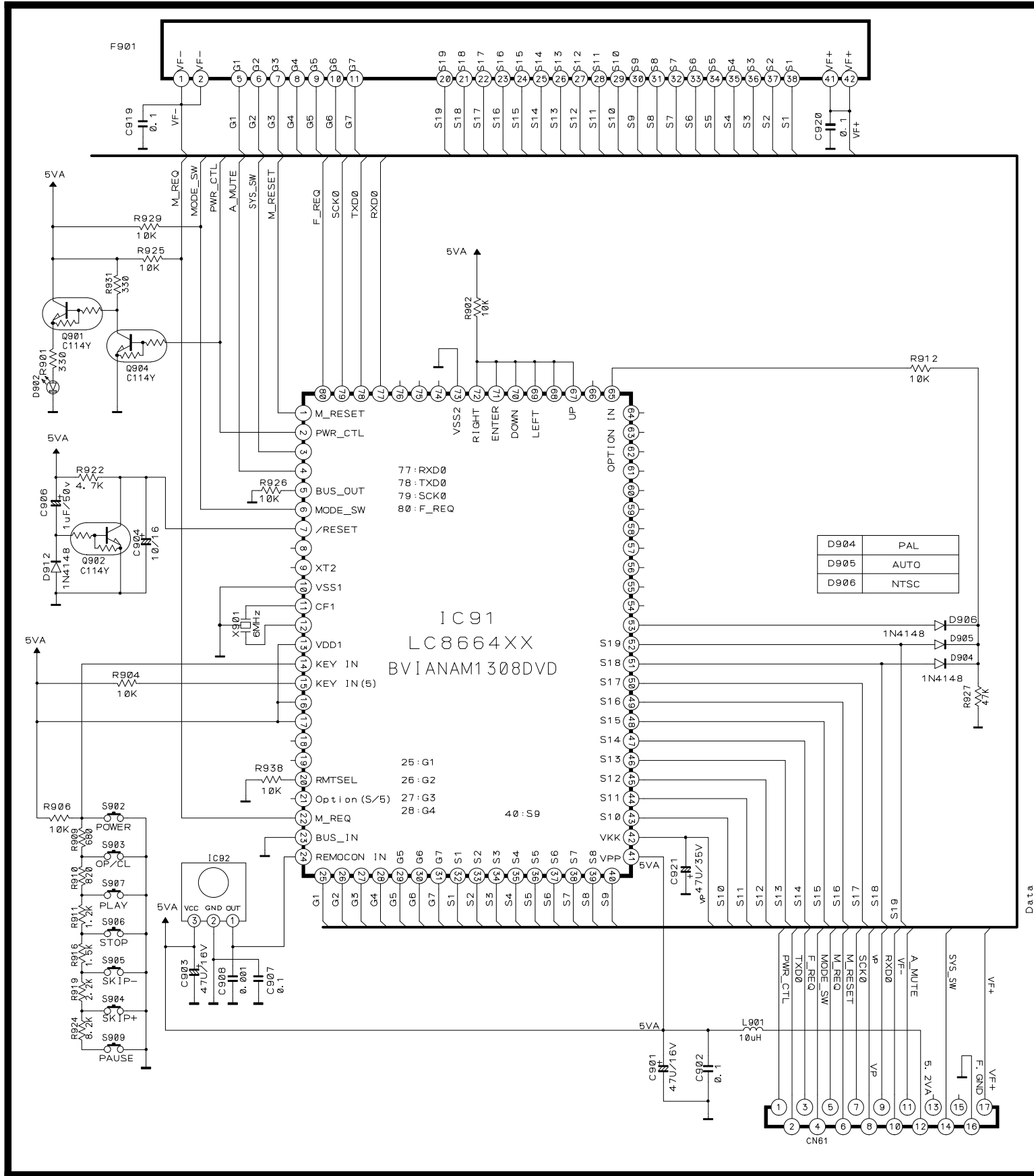

Data

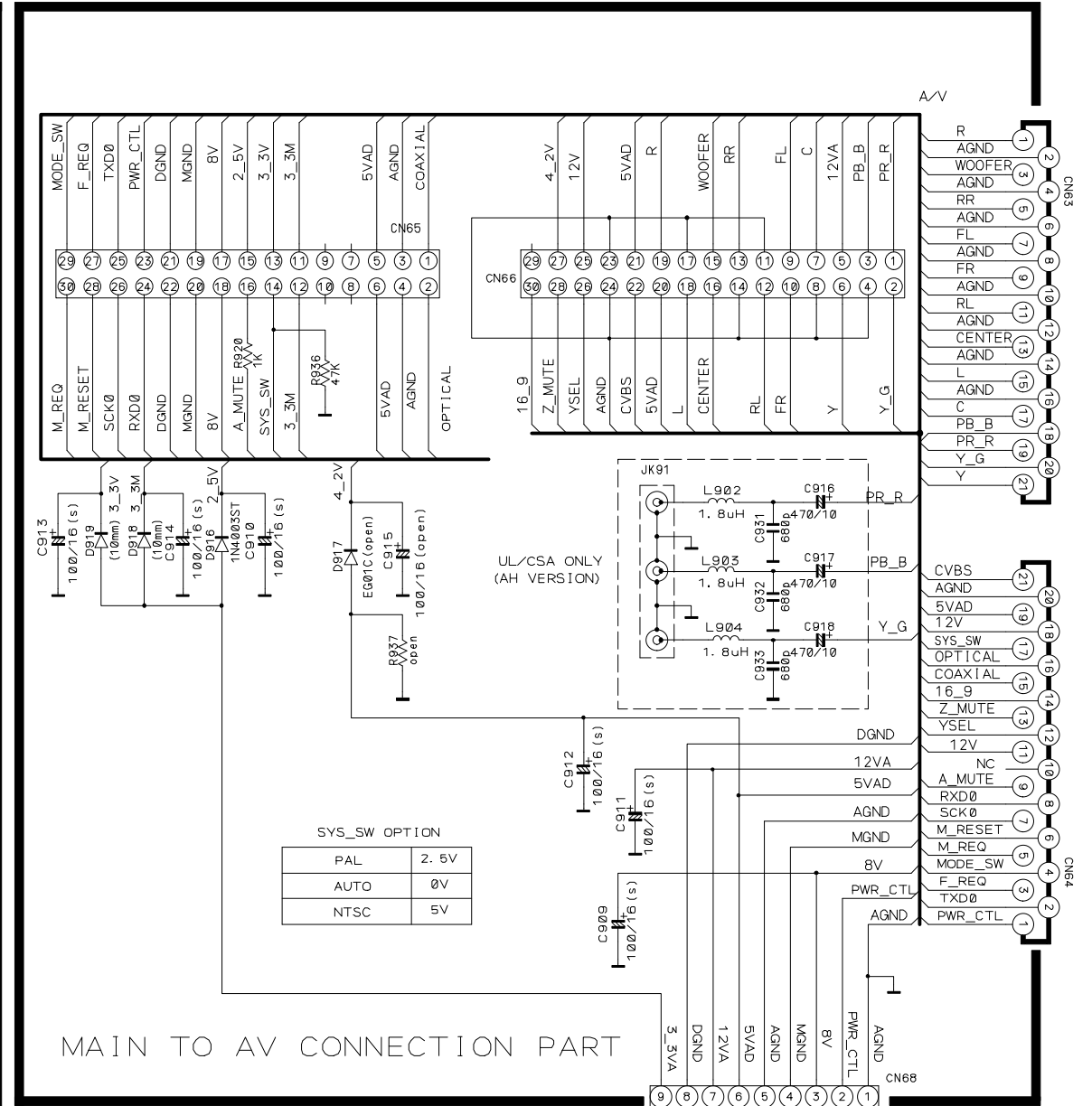

MAIN TO AV CONNECTION PART

PRINTED CIRCUIT LAYOUTS

1. MAIN P.C.BOARD

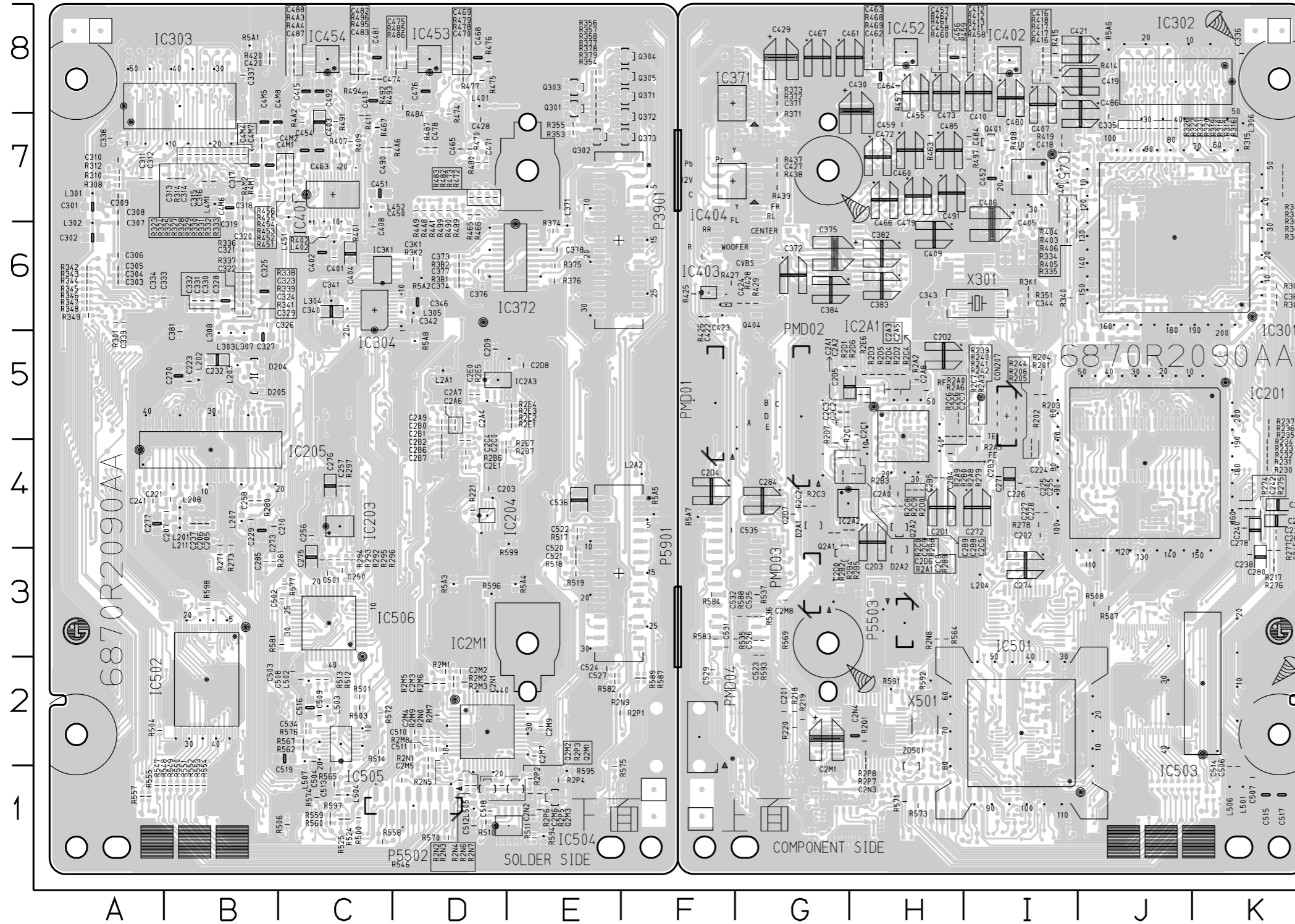

LOCATION GUIDE

(BOTTOM SIDE)

C203	D4	C306	A6	C420	B8	D205	B5	Q302	E7	R308	A7	R452	C7	R513	C2
C205	B4	C307	A6	C428	D7	IC203	C4	Q303	E8	R310	A7	R453	C7	R514	C2
C206	B4	C308	A7	C450	C7	IC204	D4	Q304	F8	R312	A7	R454	C7	R517	E3
C207	B4	C309	A7	C451	C7	IC205	B4	Q305	F8	R314	B7	R455	C7	R518	E3
C210	B4	C310	A7	C453	C7	IC2A3	D5	Q311	F8	R323	B7	R456	C7	R519	E3
C221	B4	C311	A7	C454	C7	IC2M1	D2	Q312	F7	R324	B7	R465	D7	R524	C1
C223	B5	C312	A7	C465	D7	IC303	B8	Q313	F7	R325	B7	R466	D7	R525	C1
C229	B4	C313	B7	C468	D8	IC304	D6	R221	D4	R327	B7	R467	C7	R546	D1
C232	B5	C314	B7	C469	D8	IC372	E6	R271	B4	R328	B7	R470	D7	R547	A1
C237	B4	C315	B7	C470	D8	IC3K1	C6	R273	B4	R329	B7	R472	D7	R548	A1
C241	A4	C316	B7	C471	D7	IC401	C7	R280	B4	R330	B7	R473	D7	R549	B1
C250	C3	C317	B7	C474	D8	IC453	D8	R281	B3	R331	B7	R474	D7	R550	B1
C256	C4	C318	B7	C475	D8	IC454	C8	R292	C3	R332	B7	R475	D8	R551	B1
C257	C4	C319	B7	C476	D8	IC502	B2	R293	C3	R333	B7	R476	D8	R552	B1
C258	B4	C320	B6	C478	D7	IC504	E1	R294	C3	R336	B6	R477	D8	R553	B1
C270	B5	C321	B6	C481	C8	IC505	C2	R295	C3	R337	B6	R478	D8	R554	B1
C273	B4	C322	B6	C482	C8	IC506	C3	R296	C3	R338	B6	R479	D8	R555	A1
C275	C3	C323	B6	C483	C9	L205	B6	R297	C4	R339	B6	R480	D7	R557	A1
C276	C4	C324	B6	C487	C8	L202	B5	R286	D4	R341	B6	R480	D7	R558	C1
C277	C4	C325	B6	C488	C8	L203	B5	R287	D4	R342	A6	R483	D7	R559	C1
C285	B3	C326	B6	C490	C7	L207	B4	R2E1	E5	R343	A6	R484	D8	R560	C1
C2A4	D5	C327	B5	C492	C8	L208	B4	R2E2	E5	R344	A6	R485	D8	R562	C2
C2A6	D5	C328	B6	C493	C8	L211	B4	R2E3	E5	R345	A6	R486	D8	R565	C1
C2A7	D5	C329	B6	C4M2	B7	L2A1	D5	R2E4	E5	R346	A6	R487	D7	R567	C2
C2A9	D5	C330	B6	C4M4	B7	L2A2	F4	R2E5	D5	R347	A6	R489	D7	R570	D1
C2B0	D5	C331	B6	C4M5	B7	L301	A7	R2E7	D4	R348	A6	R490	D7	R572	C2
C2B1	D5	C332	B6	C4M6	B7	L302	A6	R2M1	D2	R349	A6	R491	C7	R574	C1
C2B2	D4	C333	B6	C4M7	B7	L303	D2	R2M2	D2	R350	A6	R492	C7	R575	E1
C2B6	D4	C334	A6	C4M8	B7	L304	C6	R2M3	D2	R353	E7	R493	C8	R576	C2
C2B7	D4	C337	B8	C501	C3	L305	D6	R2M5	D2	R354	E7	R494	C8	R577	C3
C2C0	D4	C338	A7	C502	C3	L307	B5	R2M6	D2	R355	E7	R495	C8	R581	C3
C2C2	D4	C339	A6	C503	C2	L308	B5	R2M7	D2	R356	E8	R496	C8	R582	E2
C2C8	E5	C340	B6	C504	C2	L311	D8	R2M8	D2	R357	E8	R497	C7	R583	D1
C2D9	D5	C341	C6	C508	C2	L401	D8	R2M9	D2	R358	E8	R4A1	D7	R589	F2
C2E0	D5	C342	D6	C509	C2	L402	C6	R2N0	D2	R374	E6	R4A2	C7	R594	E1
C2E1	D2	C346	D6	C510	D2	L451	C7	R2N1	D2	R375	E6	R4A3	C8	R595	E1
C2M2	D2	C373	D6	C511	D2	L452	C7	R2N2	D1	R376	E6	R4A4	C2	R596	E2
C2M3	D2	C374	D6	C512	D1	L4M1	B7	R2N3	D1	R377	E8	R4A6	C7	R597	C1
C2M4	D2	C376	D6	C513	C1	L502	C2	R2N4	D1	R378	E8	R4A8	D7	R598	B3
C2M5	D1	C377	D6	C516	C2	L503	C2	R2N5	D1	R379	E7	R4A9	D7	R599	E4
C2M6	E1	C378	E6	C518	D1	L504	C1	R2N6	D1	R381	D6	R4M1	B7	R5A1	B8
C2M7	E2	C381	B6	C519	D2	L505	D1	R2N7	D2	R382	D6	R4M2	B7	R5A2	D6
C2M9	E2	C3K1	D6	C520	E3	L507	C2	R2N9	E2	R382	D6	R500	C1	R5A3	D3
C2N1	D7	C401	C6	C521	E3	P3901	E6	R2P1	E2	R401	C6	R501	C2	R5A4	E3
C2N2	E1	C402	C6	C522	E4	P5502	D1	R2P2	E1	R402	C6	R502	C2	R5A5	F4
C301	A7	C403	C7	C524	E2	P5901	E3	R2P3	D1	R407	C7	R504	A2	R5A8	D5
C303	A6	C408	C6	C527	E2	Q2M1	E1	R2P4	D1	R409	C7	R506	C1		
C304	A6	C413	C8	C536	E4	Q2M3	E1	R2P6	E1	R411	C7	R510	D1		
C305	A6	C415	C8	D204	B5	Q301	E8	R301	A6	R451	C7	R512	C2		

(TOP SIDE)

C201	G2	C207	G4	C473	H8	R201	I5	R2C4	H5	R413	I8	TP506	H3
C202	I4	C2M1	G2	C479	H7	R202	I5	R2C6	H5	R414	I8	TP507	J2
C224	I4	C2M8	G3	C480	I8	R203	I5	R2C7	I5	R415	I8	TP508	K2
C225	I4	C2N3	H1	C484	H6	R204	I5	R2C8	H4	R416	I8	TP509	J2
C227	I4	C335	J7	C486	J7	R206	I4	R200	H4	R418	I8	TP511	J2
C228	I4	C336	K8	C491	H7	R217	K3	R201	G5	R419	I7	TP512	K2
C238	K3	C343	H6	C506	K1	R218	G2	R202	H5	R425	F6	TP513	J2
C240	K4	C371	G8	C514	K1	R220	G2	R204	H5	R427	F6	TP515	J2
C242	K4	C372	G6	C515	K1	R230	K4	R205	H5	R428	G6	TP516	K2
C245	K3	C375	G6	C517	K1	R231	K4	R206	H5	R429	G6	TP517	J2
C255	I4	C380	K6	C523	G3	R232	K4	R207	G4	R437	G7	TP518	K2
C260	K4	C382	H6	C525	G3	R233	K4	R208	H5	R438	G7	TP519	J2
C271	I4	C383	H6	C526	G3	R234	K4	R2N8	H3	R439	G7	TP520	J1
C272	I4	C384	G6	C529	F2	R235	K5	R2P7	H2	R457	H8	TP521	J2
C274	I3	C405	I7	C531	F3	R236	K5	R2P8	H2	R458	I8	TP522	J1
C278	K4	C406	I6	C532	G3	R237	K5	R201	H2	R459	I8	TP523	J2
C279	K4	C407	H6	C535	F4	R239	I5	R302	K6	R460	H8	TP524	K3
C280	K3	C409	H6	CON207	I5	R240	I5	R303	K6	R461	H8	TP525	K2
C281	K4	C410	I8	D2A1	G4	R241	I5	R306	K7	R462	H8	TP526	J3
C284	G4	C411	I8	D2A2	H3	R242	I5	R307	K7	R463	H7	TP527	J3
C2A0	H4	C412	I8	IC201	J4	R244	I4	R309	K7	R468	H8	TP528	I3
C2A1	H5	C416	I8	IC2A1	H5	R274	K4	R311	K7	R469	H8	TP529	J3
C2A2	H5	C417	I8	IC2A2	G4	R275	K4	R313	K7	R497	I7	TP530	J3
C2A3	H5	C418	I7	IC301	J6	R276	K3	R315	J7	R507	J3	TP531	J3
C2A5	H5	C419	J8	IC302	J8	R277	K3	R316	J7	R508	J3	TP532	J2
C2A8	H5	C421	J8	IC371	F8	R278	I4	R317	J7	R535	G3	TP533	J2
C2B3	H4	C422	F6	IC402	I8	R279	I4	R318	J7	R536	G3	TP534	J3
C2B4	H4	C423	F6	IC403	F6	R2A0	H5	R319	J7	R537	G3	TP535	J3
C2B5	H4	C424	G6	IC404	F7	R2A1	G4	R320	J7	R564	H3	TP536	I3
C2B8	H4	C427	G7	IC451	I7	R2A2	H5	R321	J7	R569	G3	TP537	J3
C2B9	H4	C429	G8	IC452	H8	R2A3	I5	R322	J7	R571	H1	TP538	J3
C2C1	H5	C430	H8	IC501	I2	R2A5	I4	R326	J7	R573	H1	TP539	J2
C2C2	G5	C452	I7	IC503	K2	R2A6	H5	R334	I6	R583	F3	TP540	J2
C2C3	G5	C455	H8	L204	I3	R2A8	I4	R335	I6	R584	F3	TP541	J3
C2C5	H4	C456	H8	L306	K7	R2A9	H4	R340	I6	R586	G3	TP542	K3
C2C6	H5	C457	H8	L501	K1	R281	H4	R351	I6	R591	H2	TP543	K3
C2C7	H5	C458	H8	L506	K1	R282	G4	R371	G7	R592	H2	TP544	K3
C2C8	H4	C459	H7	P5503	H3	R283	H4	R372	G8	R593	G3	TP545	J2
C2C9	G4	C460	H7	PMD01	F5	R284	G4	R373	G8	R5A6	J8	TP546	J2
C2D0	G4	C461	H8	PMD02	G5	R285	H4	R374	G8	R5A7	F4	TP547	I3
C2D1	H4	C462	H8	PMD03	G3	R288	H4	R403	I7	TP2A1	H5	TP548	I3
C2D2	H5	C463	H8	PMD04	F2	R289	H4	R404	I7	TP501	K2	TP549	J3
C2D3	H4	C464	H8	Q2A1	G3	R2C0	G4	R405	I6	TP502	J2	X301	I6
C2D4	F4	C466	H7	Q2A2	H4	R2C1	G4	R406	I7	TP503	H3	X501	H2
C2D5	H5	C467	G8	Q401	I7	R2C2	G4	R407	I7	TP504	H3	Z0501	H1
C2D6	F4	C472	H7	Q404	F6	R2C3	G4	R412	I8	TP505	H3		

2. POWER P.C.BOARD

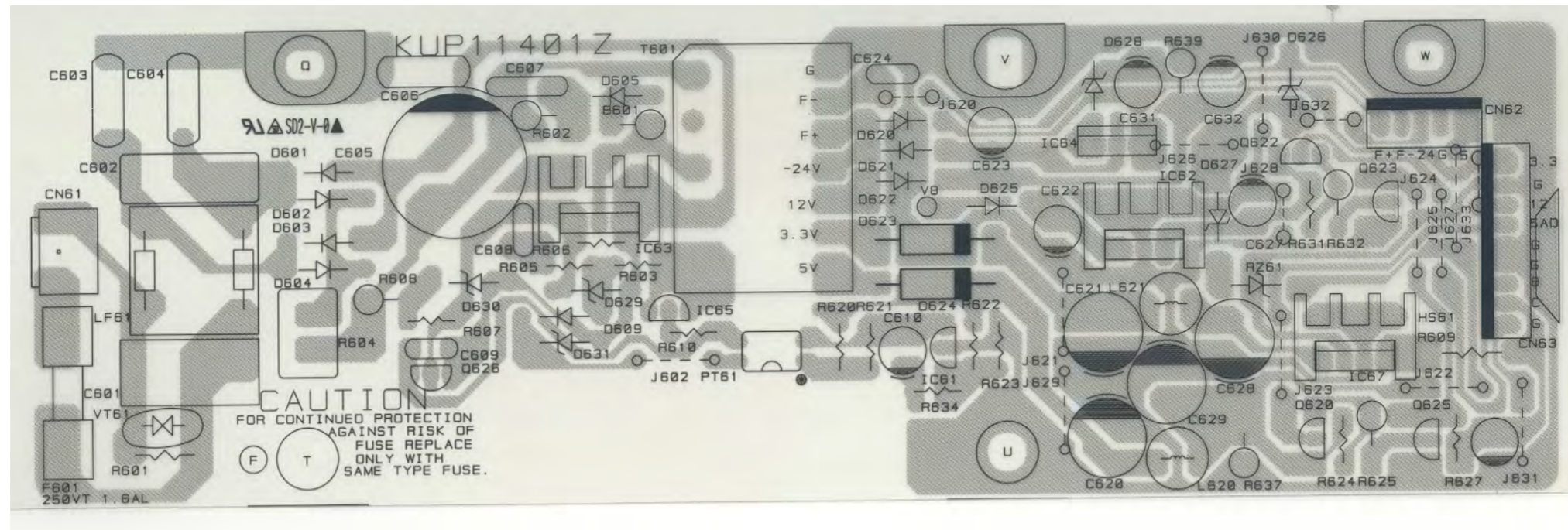

3. AV P.C.BOARD

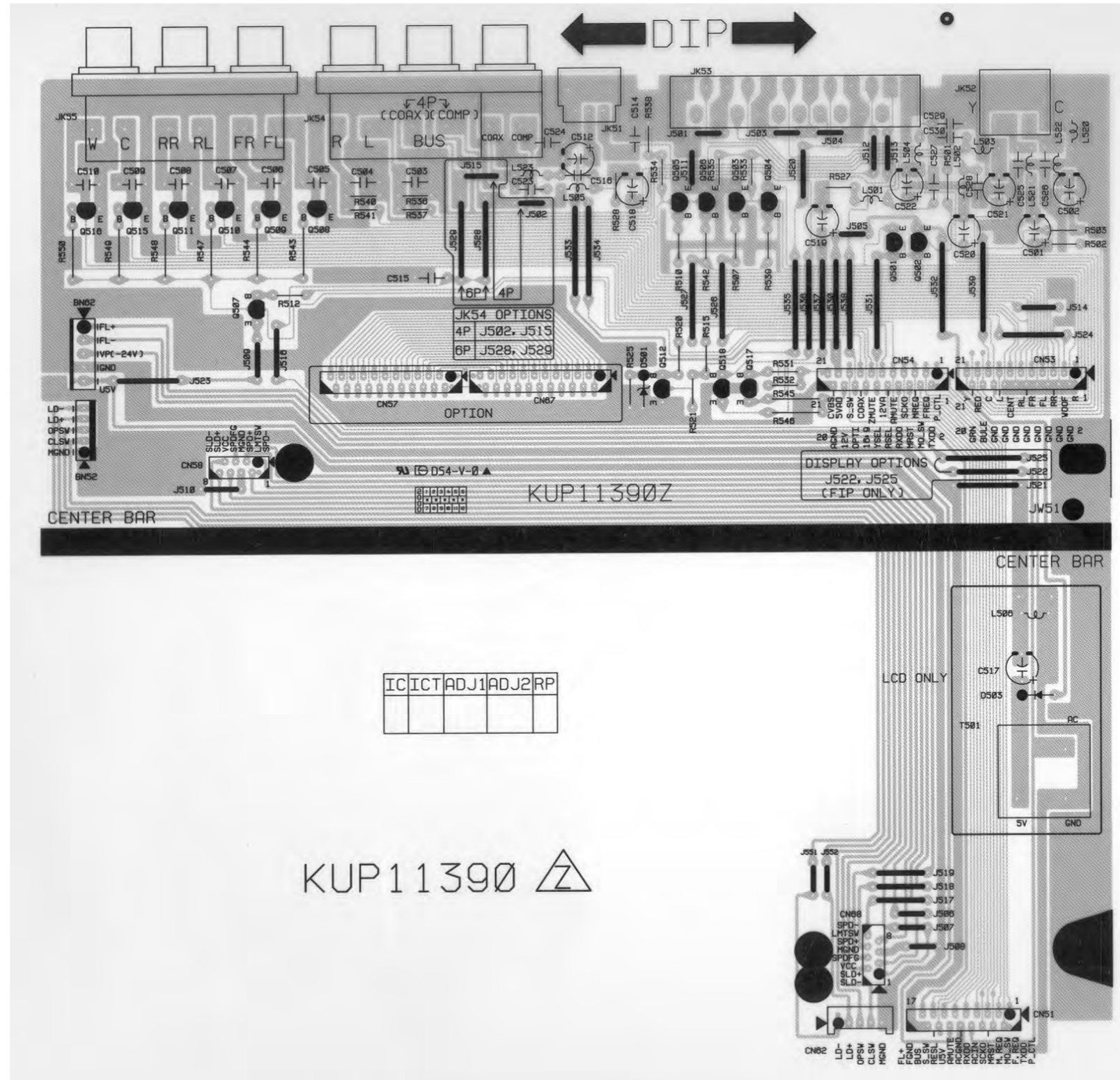

IC	ICT	ADJ1	ADJ2	RP

KUP11390 

4. FRONT P.C.BOARD

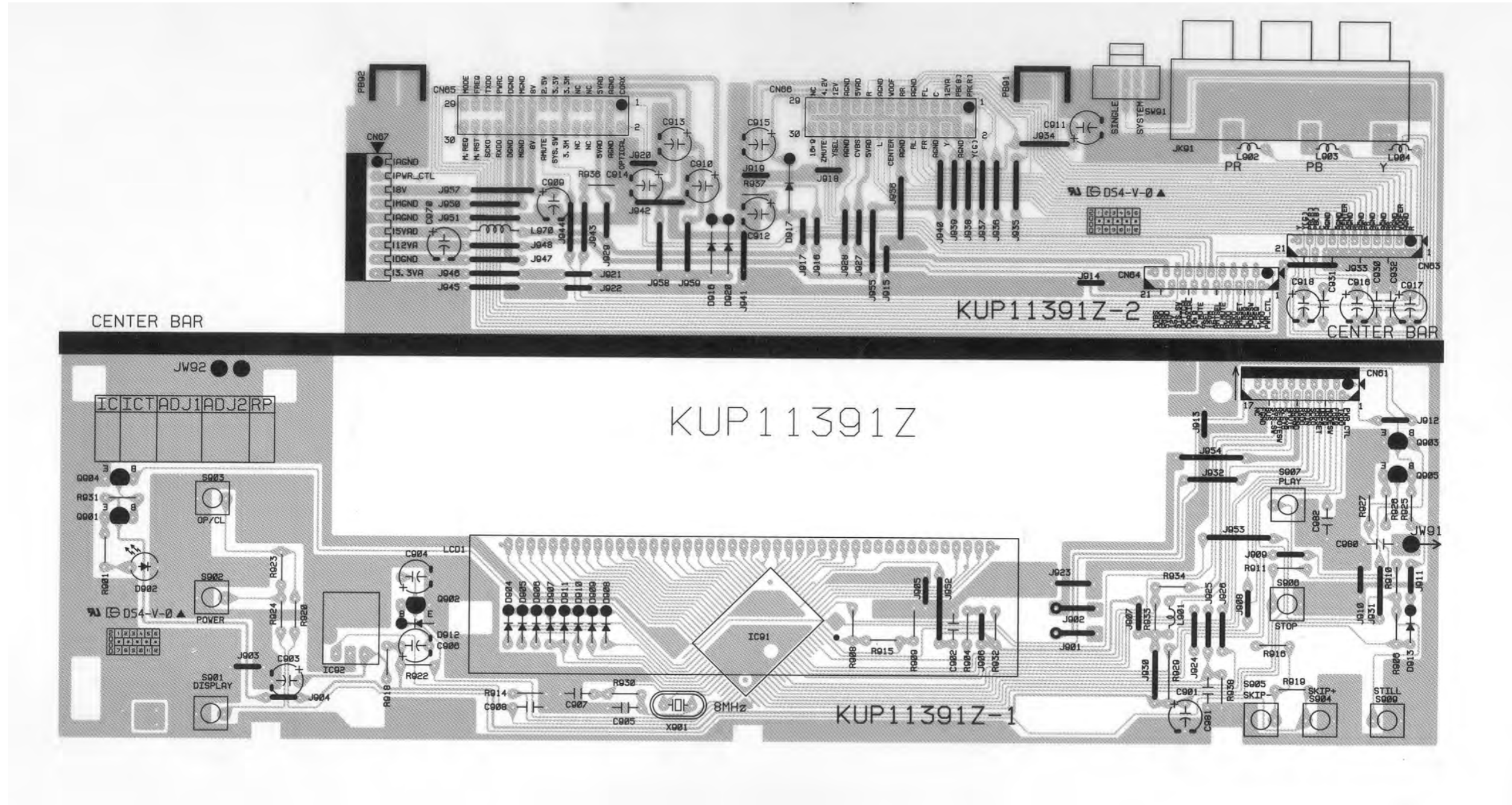

SECTION 4 MECHANISM

CONTENTS

DECK MECHANISM PARTS LOCATIONS

- Top View.....4-2
- Top View(without Tray Disc)4-2
- Bottom View4-2

DECK MECHANISM DISASSEMBLY

1. Holder Clamp.....4-2

- 1-1. Clamp Assembly Disc.....4-2
 - 1-1-1. Plate Clamp4-2
 - 1-1-2. Magnet Clamp4-2
 - 1-1-3. Clamp Upper.....4-2

2. Tray Disc4-2

3. Base Assembly Sled4-3

- 3-1. Gear Assembly Feed.....4-3
- 3-2. Gear Assembly Middle.....4-3
- 3-3. Gear Assembly Rack.....4-3

4. Rubber Rear.....4-3

- 5. Frame Assembly Up/Down4-4
- 6. Belt Loading.....4-4
- 7. Gear Pulley4-4
- 8. Gear Loading4-4
- 9. Guide Up/Down.....4-4
- 10. PWB Assembly Loading4-4
- 11. Base Main.....4-4

DECK MECHANISM PARTS LOCATION

• Top View (With Tray)

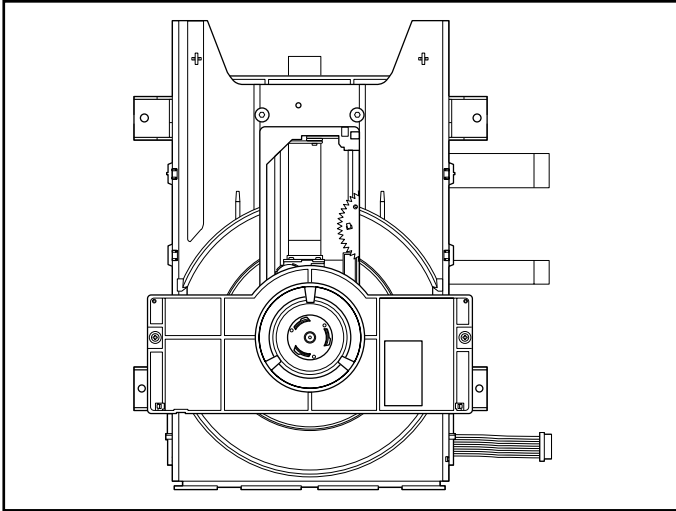

• Top View (Without Tray)

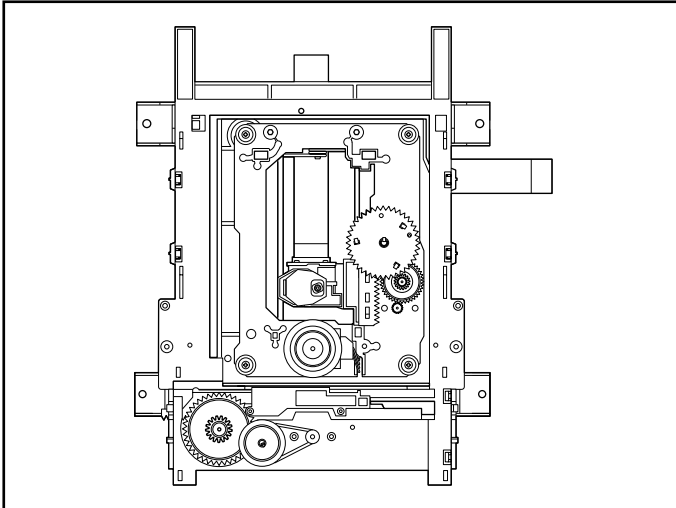

• Bottom View

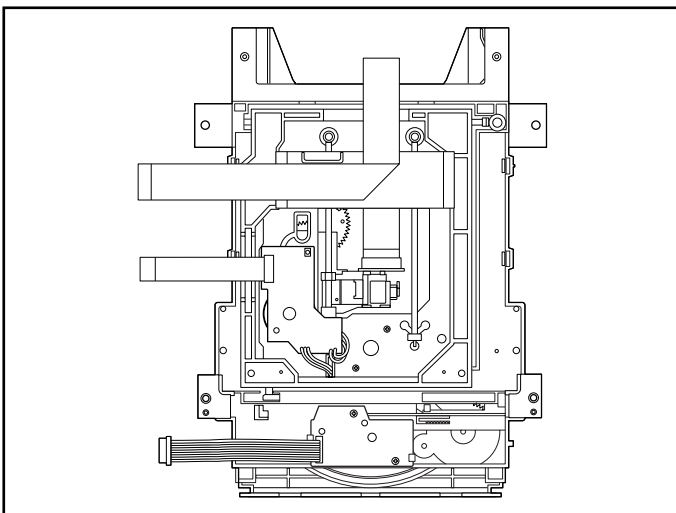

Procedure		Parts	Fixing Type	Disassembly	Figure
Starting No.					
	1	Holder Clamp	2 Screws, 2 Locking Tabs		4-1
1	2	Clamp Assembly Disc			4-1
1, 2	3	Plate Clamp			4-1
1, 2, 3	4	Magnet Clamp			4-1
1, 2, 3, 4	5	Clamp Upper			4-1
1	6	Tray Disc			4-2
1, 6	7	Base Assembly Sled			4-3
1, 2, 6	8	Gear Assembly Feed	4 Screws, 1 Connector 1 Locking Tabs		4-3
1, 2, 6, 8	9	Gear Middle			4-3
1, 2, 6, 8, 9	10	Gear Assembly Rack	1 Screw		4-3
1, 2, 7	11	Rubber Rear			4-3
1, 2, 7	12	Frame Assembly Up/Down	1 Screw	Bottom	4-4
1, 2	13	Belt Loading	1 Locking Tab		4-4
1, 2, 13	14	Gear Pulley			4-4
1, 2, 13, 14	15	Gear Loading	1 Locking Tab		4-4
1, 2, 7, 12, 13, 14	16	Guide Up/Down			4-4
1, 2, 13	17	PWB Assembly Loading	1 Locking Tab 1 Hook 2Screw	Bottom	4-4
1, 2, 7, 12, 13, 14, 15, 16, 17	18	Base Main	2 Locking Tabs		4-4

Note

When reassembling, perform the procedure in reverse order.

The "Bottom" on Disassembly column of above Table indicates the part should be disassembled at the Bottom side.

DECK MECHANISM DISASSEMBLY

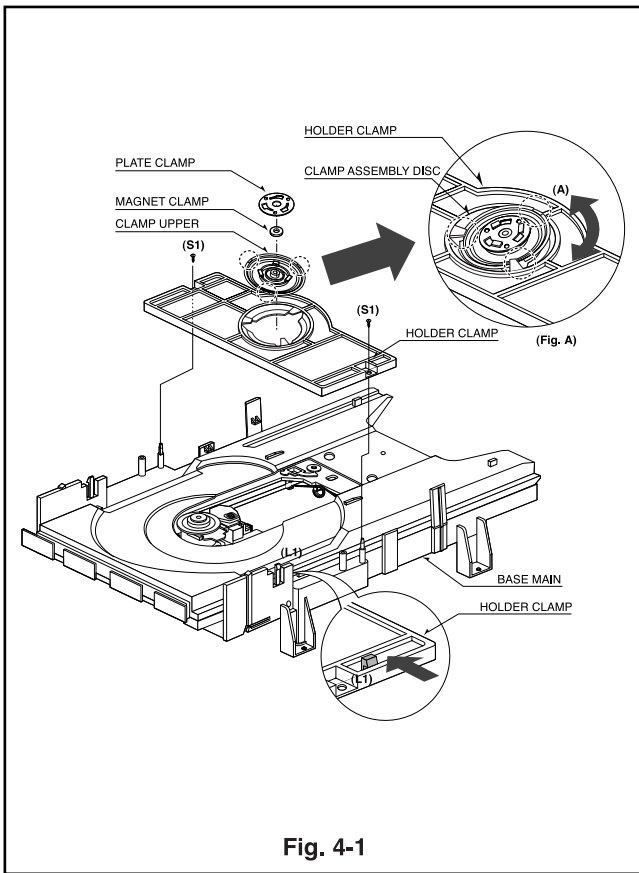

Fig. 4-1

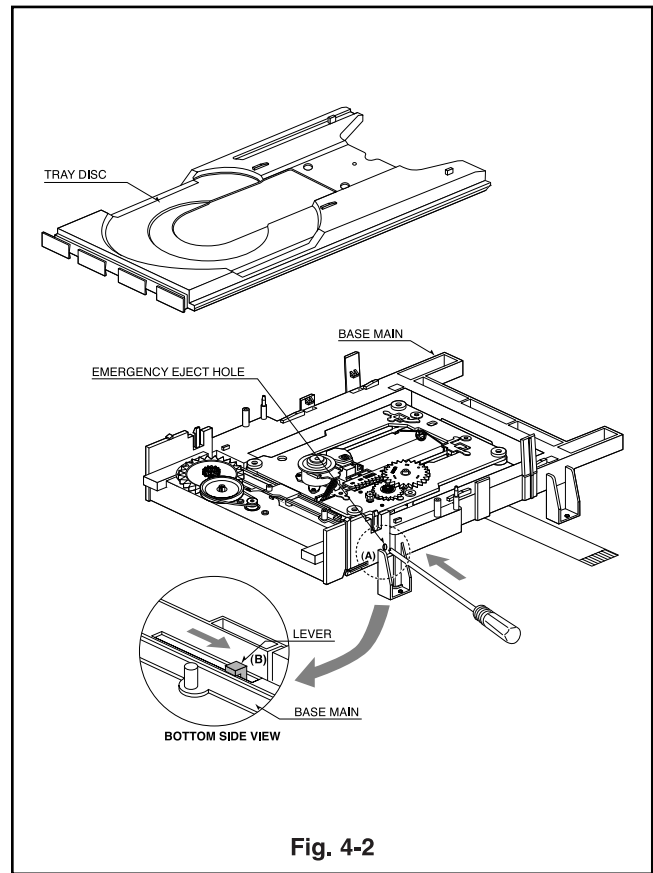

Fig. 4-2

1. Holder Clamp (Fig. 4-1)

- 1) Release 2 Screws(S1).
- 2) Unhook 2 Locking Tabs(L1).
- 3) Lift up the Holder Clamp and then separate it from the Base Main.

1-1. Clamp Assembly Disc

- 1) Place the Clamp Assembly Disc as Fig. (A)
- 2) Lift up the Clamp Assembly Disc in direction of arrow(A).
- 3) Separate the Clamp Assembly Disc from the Holder Clamp.

1-1-1. Plate Clamp

- 1) Turn the Plate Clamp to counterclockwise direction and then lift up the Plate Clamp.

1-1-2. Magnet Clamp

1-1-3. Clamp Upper

2. Tray Disc (Fig. 4-2)

- 1) Insert and push a Driver in the emergency eject hole(A) at the right side, or put the Driver on the Lever(B) of the Gear Emergency and pull the Lever(B) in direction of arrow so that the Tray Disc is ejected about 15~20mm.
- 2) Pull the Tray Disc until it is separated from the Base Main completely.

DECK MECHANISM DISASSEMBLY

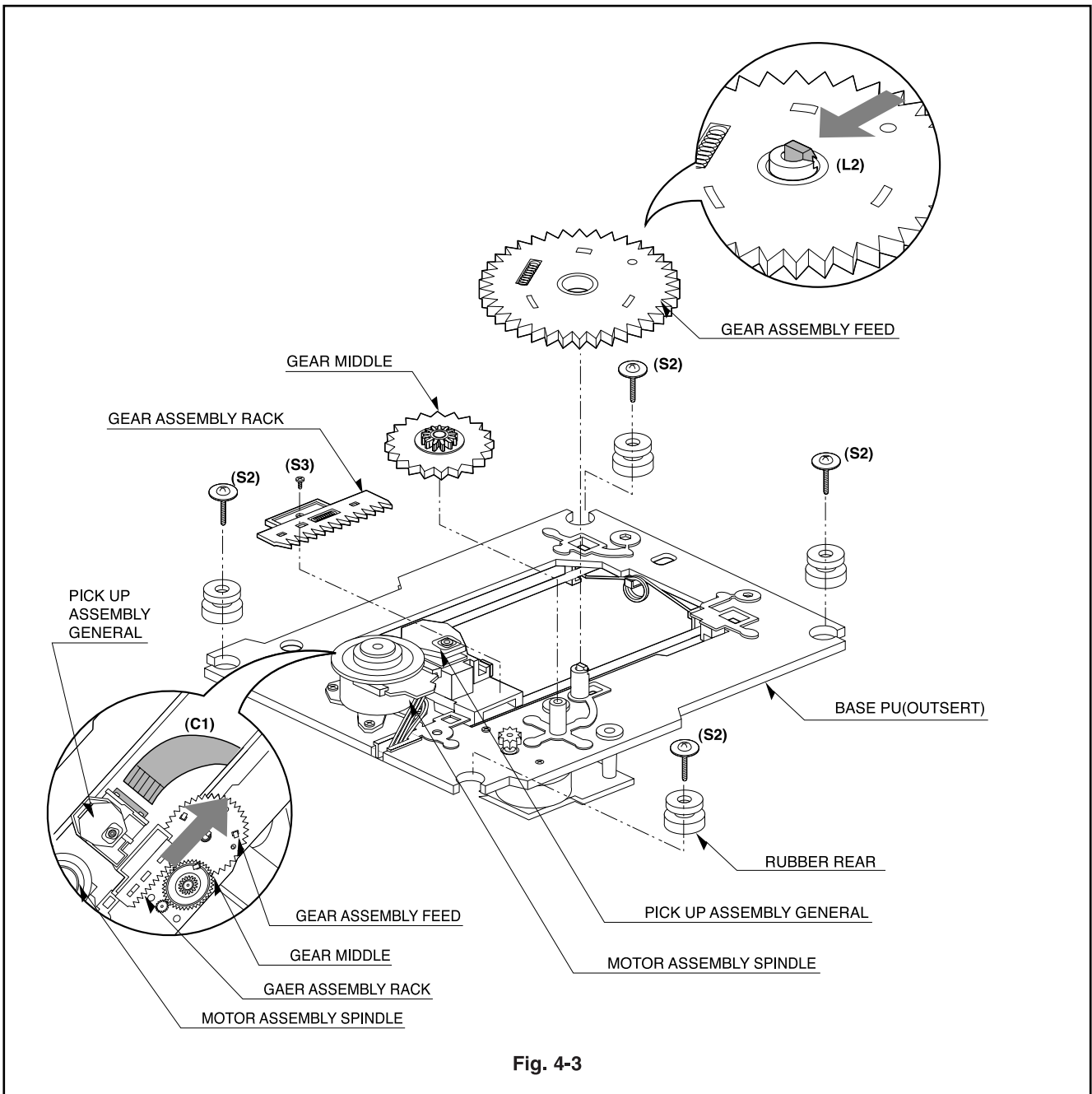

Fig. 4-3

3. Base Assembly Sled (Fig. 4-3)

- 1) Release 4 Screw(S2).
- 2) Disconnect the FFC Connector(C1)

3-1. Gear Assembly Feed

- 1) Unhook the Locking Tab(L2) in direction of arrow.

3-2. Gear Middle

3-3. Gear Assembly Rack

- 1) Release the Scerw(S3)

4. Rubber Rear (Fig. 4-3)

DECK MECHANISM DISASSEMBLY

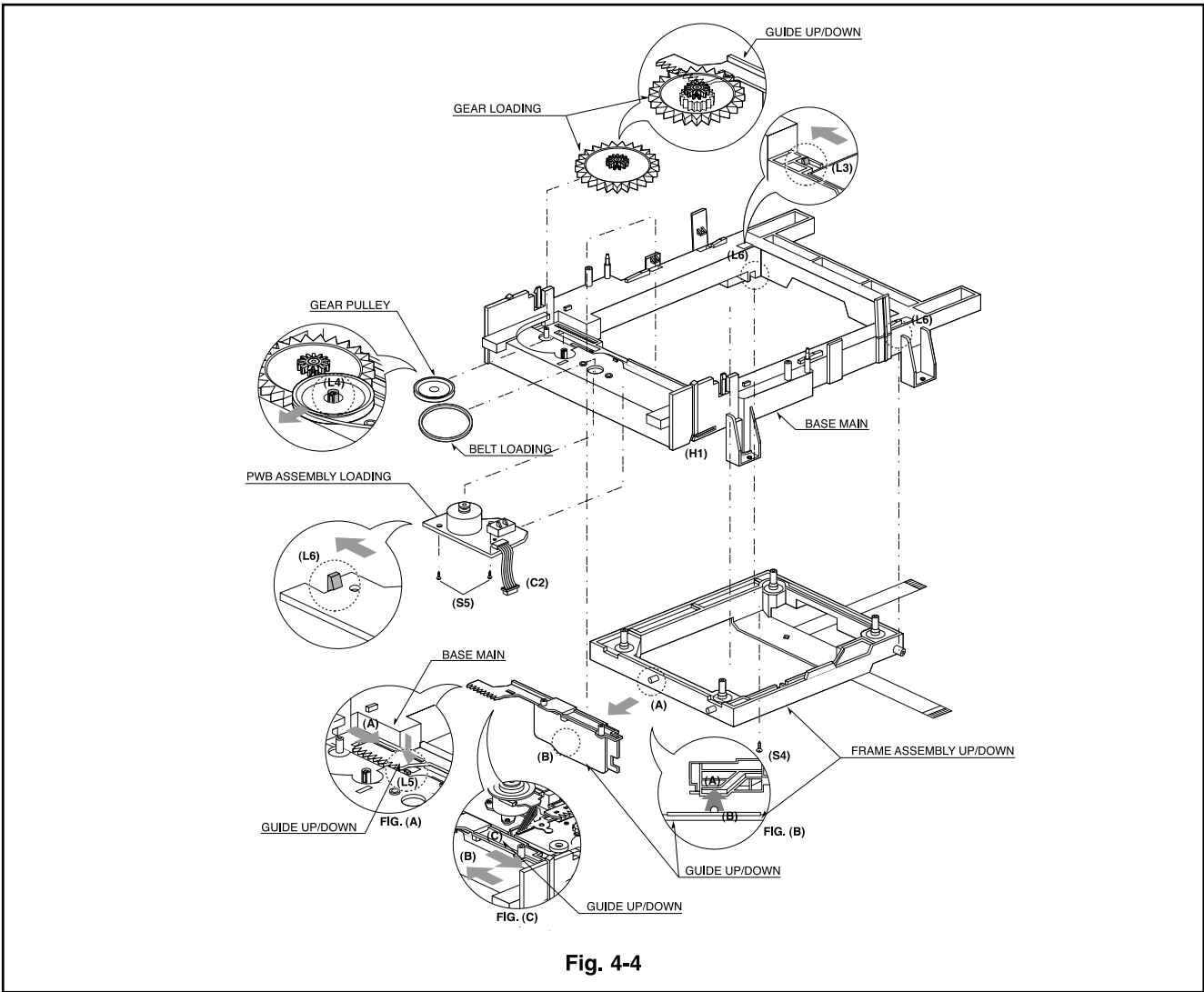

Fig. 4-4

5. Frame Assembly Up/Down

Note

Put the Base Main face down(Bottom Side)

- 1) Release the Screw(S4)
- 2) Unlock the Locking Tab(L3) in direction of arrow and then lift up the Frame Assembly Up/Down to separate it from the Base Main.

Note

- When reassembling move the Guide Up/Down in direction of arrow(C) until it is positioned as Fig.(C).
- When reassembling insert (A) portion of the Frame Assembly Up/Down in the (B) portion of the Guide Up/Down as Fig.(B)

6. Belt Loading(Fig. 4-4)

Note

Put the Base Assembly Main on original position(Top Side)

7. Gear pulley (Fig. 4-4)

- 1) Unlock the Locking Tab(L4) in direction of arrow(B) and then separate the Gear Pulley from the Base Main.

8. Gear Loading (Fig. 4-4)

9. Guide Up/Down (Fig. 4-4)

- 1) Move the Guide Up/Down in direction of arrow(A) as Fig.(A)
- 2) Push the Locking Tab(L5) down and then lift up the Guide Up/Down to separate it from the Base Main.

Note

When reassembling place the Guide Up/Down as Fig.(C) and move it in direction arrow(B) until it is locked by the Locking Tab(L5). And confirm the Guide Up/Down as Fig.(A)

10. PWB Assembly Loading

Note

Put the Base Main face down(Bottom Side)

- 1) Release 2 Screws(S5)
- 2) Unhook the Loading Motor Connector (C2) from the Hook (H1) on the Base Main.
- 3) Unlock 2 Locking Tabs(L6) and separate the PWB Assembly Loading from the Base Main.

11. Base Main(Fig. 4-4)

SERVICE MANUAL

L56
DVD/VIDEO CD/CD
PLAYER

© NAD 2003

NAD ELECTRONICS INTERNATIONAL
TORONTO